



SKUTT

KILNMASTER

OPERATING MANUAL



New Mexico Clay

3300 Girard NE Albuquerque NM 87107

505-881-2350 www.nmclay.com

6441 SE Johnson Creek Blvd.. Portland, OR 97206 (503) 774-6000 skutt@skutt.com

www.skutt.com

REVISED 1/19/09

Thank You!



Dear Kiln Owner,

Thank you for purchasing a Skutt Kiln. At Skutt we have been committed to making quality products and supporting them with the best customer service possible for over 50 years. If for any reason you feel we are not delivering on this commitment, please let us know so we can do our best to make things right.

Kilns are very safe and easy to operate pieces of equipment when you take the time to understand how they work. Even if you are an experienced kiln operator you will want to read this manual to take advantage of the many new features incorporated into the design of this latest generation of KilnMaster Kilns.

In the new KilnMasters, there are many advanced features that are designed for our technicians to access data when helping you to troubleshoot your kiln. There are also some advanced programming techniques that you may never need. If you don't quite understand them, don't worry about it. Just remember they are there if you do need them.

If at anytime you need further explanation, please feel free to contact us or your local Skutt distributor.

Again, on behalf of Skutt Kilns, thank you for buying a Skutt Kiln.

Sincerely,

Brant Palley

New Mexico Clay

Jim Skutt
President

~ **BE SAFE** ~

Tens of thousands of kilns are used safely in homes, schools, and professional studios throughout the world. With a good understanding of your kiln and a little common sense you can avoid any accidents. Please observe the following safety recommendations:

OPERATION

- The stainless steel jacket and some of the other fixtures surrounding the kiln will get hot enough to burn your skin when the kiln is heated. Therefore, it is important to be extremely careful when working close to the kiln. We recommend posting warning signs of this potential hazard in the kiln room.
- Keep anyone who cannot understand warning signs such as small children and pets away from the kiln when it is firing.
- Be careful when opening the kiln door while the kiln is heated. We recommend you use fire rated gloves to protect your skin and make sure clothing is kept well away from any kiln opening or hot kiln surface.
- The elements inside the kiln chamber will cause an electrical shock if touched. Never insert metal instruments or place any part of your body into the kiln while it is firing.
- Always be sure to unplug the kiln before working on the electrical components. If the kiln is hard wired, turn off the circuit breaker.
- Plan on being with the kiln when it is scheduled to turn off.
- Remove all potentially combustible materials from the kiln area.
- Long term viewing inside the kiln chamber can cause damage to your eyes. Therefore, it is recommended that you use IR and UV protective glasses when looking into the kiln for extended periods of time. #3 welders green or gray glasses will protect your eyes.
- Be cautious of intense heat around the peep holes when peep plugs are removed.
- In the event of a severe storm, unplug your KM kiln. Exposure to static shock or electrical surges can damage the circuit board in the controller.
- The kiln lids on many models are heavy. Make sure the lid brace is secure before releasing the lid. Make sure the hardware that secures the lid brace is secure and not corroded.
- Do not place anything in the kiln you are unsure of. Certain items may potentially melt, explode, or release toxic fumes. Items that may be damp (i.e. greenware, kiln shelves) have the potential to crack or explode inside the kiln when the moisture trapped inside them turns to vapor when heated.
- Never allow your kiln to exceed the temperature rating listed on the serial plate.
- For your safety, the protection of your kiln, and the protection of your ware inside the kiln, we recommend that you avoid unloading the kiln when it is above 125°F



INSTALLATION

- As with all electrical products there is danger of electrical shock. Use only properly sized and rated copper wire when installing the power supply for your kiln. We recommend this work is done by a licensed electrician
- Kilns should always be located in a dry place to prevent electrical shock and corrosion.
- Follow all instruction for installation in this manual. Always observe fire, building and safety codes when installing any Skutt Product.
- If there are fire sprinklers located in the kiln room make sure they are rated high enough so they will not be set off when the kiln is at peak temperature. This should be tested with the kiln at peak temperature, the ventilation system turned off and all doors and windows closed for maximum insurance.
- We recommend having a fire extinguisher rated for electrical fires easily accessible near the kiln.
- Skutt Ceramic Products Inc. will not assume liability for injury or damages caused by variations from the instructions put forth in this manual.
- Kilns get hot. Observe all instructions to ensure proper clearances from flammable or temperature sensitive objects and living things.
- Ventilation is key to maintaining a healthy work environment and proper room temperature. Proper installation of a Skutt Envirovent 2 will clear potentially harmful fumes from the room. To ensure proper room temperature is maintained consult a qualified HVAC professional.
- The proper placement of thermocouples is crucial to the proper operation of all automatically controlled kilns. Check all thermocouples for damage and correct placement. Thermocouples must protrude into the kiln chamber at least 1” to ensure an accurate reading.
- Only use the stand that is designated by Skutt Ceramic Products for your particular kiln model. Other stands may not properly support the weight of your kiln, provide adequate clearance, and could pose a fire hazard.
- The power cord is sized correctly to handle the power for your particular kiln. Never use an extension cord.
- Make sure the power cord is routed in such away as to not touch any portion of the kiln that gets hot.
- Be careful of pinch hazards when working on or assembling the kiln.
- Be sure to properly tension the springs on kilns equipped with lid lifters.

MAINTENANCE

- Always unplug the kiln before performing any repairs or general maintenance. If your kiln is wired direct, turn off the breaker.
- Use only Skutt replacement parts. Improperly sourced parts may pose a hazard to you and your kiln and void your warranty.
- Never modify your kiln without first consulting Skutt. Improper modifications may pose a hazard to you and your kiln and void your warranty.. Items such as alternative thermocouples, controllers, kiln coatings may ruin your kiln if improperly installed or applied.
- Replace any electrical components that are discolored ,brittle, or corroded.
- band from slipping or flexing.

PRECAUTIONS FOR THE KILNMASTER CONTROLLER

- The controller is a temperature control device. It is not a safety device.
- The maximum operating temperature is 100°F (38°C). This temperature refers to the room temperature while the kiln is firing and does not pertain to the internal temperature of the kiln.
- The minimum operating temperature is 33°F (1°C).
- The controller contains static-sensitive parts that may be damaged by static electricity. Use caution to avoid creating static that may damage the equipment. In areas where static electricity is common, or during dry times of the year throughout the country, touch the kiln lid handle before touching the controller to discharge the static.

LETTER FROM THE PRESIDENT	2
SAFETY	3
QUICK START	8
CONE FIRE	8
RAMP/HOLD	8
SET-UP	9
CONTENT LIST	9
ANATOMY OF A KILN	9
ELECTRICAL CHECK LIST	10
LOCATING THE KILN	10
PREPARATION	11
TEST FIRING.....	12
PROGRAMMING.....	13
GENERAL PROGRAMMING INFORMATION.....	13
LED DISPLAY.....	13
IDLE MODE.....	13
START/STOP/ENTER	13
DELAY.....	13
ALARM	14
MENU	14
REVIEW	14
VIEW	14
CONE TABLE	14
DURING THE FIRING	15
AFTER THE FIRING	15
FINE TUNING YOUR KILN	15
CHOOSING A PROGRAMMING MODE	16
PROGRAMMING CONE FIRE MODE.....	17
ADVANCED CONE FIRE MENU FEATURES	19
WRITING CUSTOM CONE FIRE PROGRAMS	19
SLOW COOLING (CONE FIRE CONTROLLED COOLING)	19
PROGRAMMING RAMP/HOLD MODE	20
ADVANCED FEATURES	22
16 SEGMENT PROGRAMS.....	22
CONE CORRELATION	22
RUNNING A STORED RAMP/HOLD PROGRAM	22
MENU FEATURES	23
KILN MASTER MENU TREE	23
NEW FEATURES	24
NEW MENU LAYOUT.....	24
GENERAL PROGRAMMING TIPS	24

PROGRAMMING INSTRUCTIONS	25
SETTINGS.....	25
DIAGNOSTICS	25
CONFIGURATION.....	26
OTHER	30
TROUBLESHOOTING.....	31
GETTING HELP	31
ERROR CODES.....	31
QUESTIONS AND ANSWERS	36
PREVENTATIVE MAINTENANCE.....	38
REPAIRS.....	39
REPLACING WALL BRICK	39
LID MAINTENANCE	40
FLOOR REPAIRS	40
REPLACING ELEMENTS	40
REPLACING THERMOCOUPLE ELEMENT ON KM AUTOMATIC KILNS	41
KILNMASTER CONTROLLER CIRCUITRY	41
APPENDICES.....	42
APPENDIX 1 — DISASSEMBLING MULTI-SECTION KILNS	42
APPENDIX 2 — USING THE LID LIFTER	42
APPENDIX 3 — HEAT WORK (CONES)	44
APPENDIX 4 — LOADING TIPS.....	45
APPENDIX 5 — ELECTRICAL REQUIREMENTS	46
APPENDIX 6 — SET-UP AND SPECIFICATIONS FOR SKUTT PK KILNS.....	49
APPENDIX 7 — SETUP FOR THE KM 1627	51
APPENDIX 8 — THE WALL-MOUNTED KILNMASTER CONTROLLER	53
APPENDIX 9 - PRIMARY DISPLAY MESSAGES	55
WIRING DIAGRAMS.....	57
MY PROGRAMS	66

QUICK START

Quick Start is a memory aid, not a substitute to reading and understanding the manual.

Activate the power source by plugging in the kiln or controller. After plugging in the kiln, the display will read **WAIT** for approximately 10 seconds while power is restored to the kiln. It will then switch to Idle Mode. In Idle Mode the display will flash the kiln temperature alternating with **IdLE**. Begin all programming in Idle Mode.

Be sure the programmer is set to the right temperature scale before proceeding (Fahrenheit or Celsius).

CONE FIRE MODE

Step 1

- Press **CONE FIRE**

Step 2

Input **PREHEAT** time.
Press **ENTER**

Step 3

- Input Cone number.
Press **ENTER**

Step 4

- Input a **SPEED**
Press **ENTER**

Step 5

- Input **HOLD** time
Press **ENTER**

Step 6

- Press **START**.

THE RAMP/HOLD MODE

Step 1

- Press **RAMP/HOLD**.

Step 2

- Input the **PROG** Number
Press **ENTER**

Step 3

- Input the number of segments
Press **ENTER**

Step 4

- Input the first heating rate
Press **ENTER**

Step 5

- Input the first temperature to reach.
Press **ENTER**

Step 6

- Input **HOLD** time.
Press **ENTER**

Step 7

- Repeat steps 4 through 6
until alarm flashes
Press **ENTER**

Step 8

- Press **START**

Your Skutt kiln has traveled a long way by rail or truck. Look for any signs of damage caused by transit. If damage is found, call your freight agent and ask for an inspection.

Do not discard the packing materials, they may be needed later.

CONTENTS LIST

Skutt Kilns should arrive fully assembled. Packed with the kiln you will find the following items:

- Kiln Stand
- Instructional Video
- Operating Manual
- Stand Feet
- Extra Thermocouple (unless Type S)
- Warranty Card
- Peep Plugs - attached to the kiln stand, enough to fill each peephole on your particular model.



ANATOMY OF A KILN

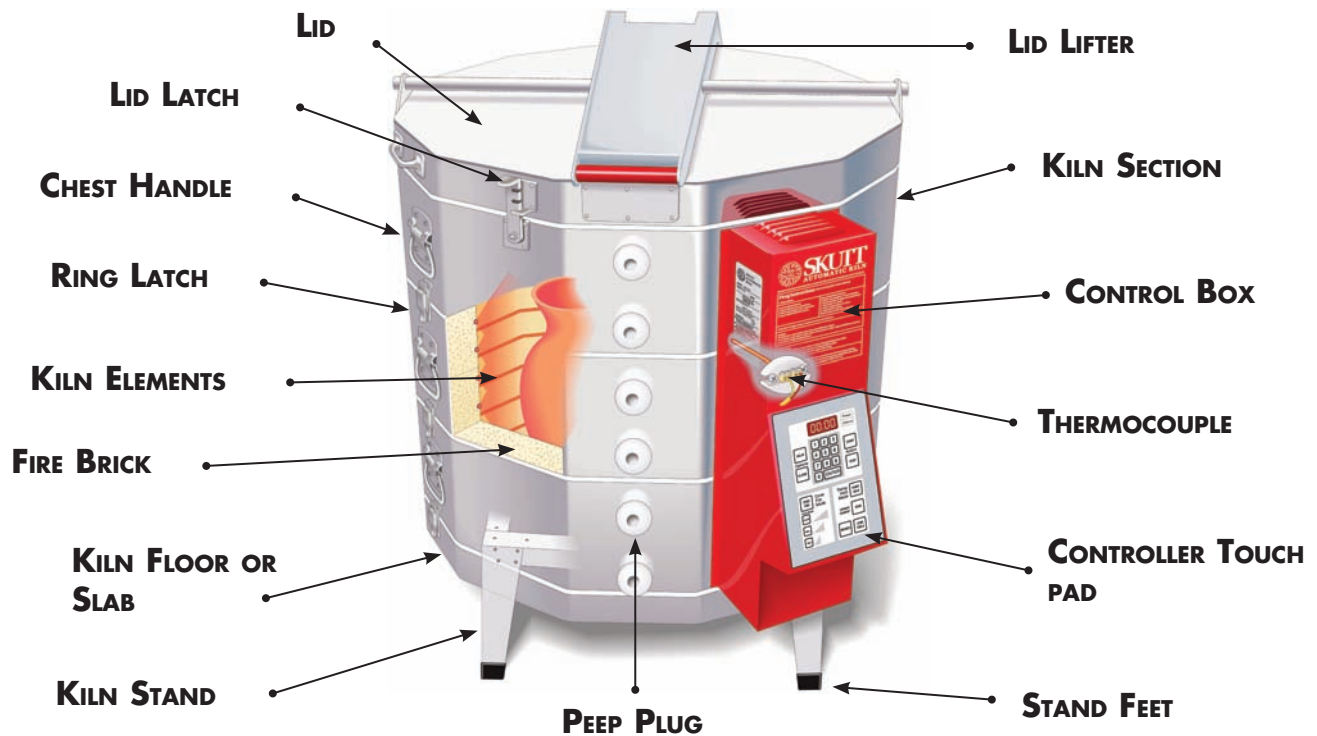

ELECTRICAL CHECK LIST

Make sure serial plate matches electrical supply, if you are not sure, consult an electrician. See Appendix 5 Electrical Requirements.

LOCATING THE KILN

- Locate your kiln near your present electrical outlet or where a new circuit can be installed. Position the kiln to the left of your electrical outlet so the cord will have an easy run and will not place a strain on the plug or outlet.
- Install it in a well ventilated, sheltered area such as a carport, garage, utility or hobby room. Allow a **MINIMUM 18 INCHES (46 cm)** of space between your kiln and adjacent walls, other kilns, shelving, etc. When multiple kilns will be installed in the same room, make sure the control boxes on the kilns are not facing adjacent kilns. Radiant heat from nearby kilns can damage the controller.
- For small rooms, monitor the firing so room temperatures does not exceed 105°F (41°C). Do not fire if room temperatures are 32°F (0°C) or less as damage to the electronic components may result. Below is an example of a typical room layout.
- Locate the kiln in a room with a bare cement floor. If a bare cement floor is not available, the uniform mechanical code requires two inches of masonry below the kiln extending a minimum of 12" (31 cm) beyond the outside circumference of the kiln.
- When installing a kiln in a room with a fire control sprinkler system, do not place kilns within a 10 ft. (3m) radius below sprinkler heads. If this is not possible, contact Skutt for alternative solutions before installing.
- All kilns are vulnerable to the highly corrosive effects of marine air. If you live near salt water, locate the kiln indoors and protect it from the damp air.

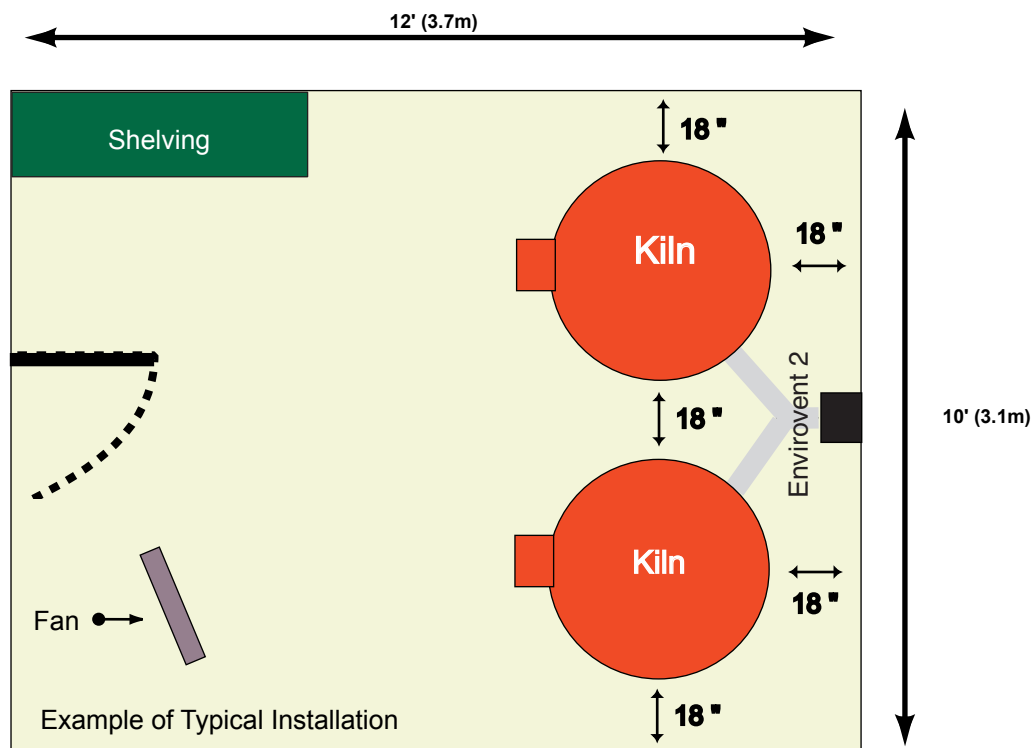

PREPARATION

Certain kiln models may have slightly different set-up instructions. Special set-up instructions for PK Kilns and the KM-1 Wall Mount Controller are located in the Appendices Section.

- Save packing material until test fire is complete. The kiln comes almost completely assembled. If you need to disassemble the kiln to make it lighter or smaller to move through doorways, see Appendix 1

LOAD THE LID LIFTER SPRINGS

If your kiln is equipped with a spring assisted Lid Lifter, you will need to load the springs. They have been de-tensioned to avoid damage to the kiln during shipping. Please consult Appendix 2 for instructions on tensioning the springs.

REMOVE AND SET-UP STAND

STEP 1

- Open the lid and secure the lid brace in place.

STEP 2

- Slightly bend the stand packing cardboard to relieve the tension against the brick wall and carefully lift the stand out of the kiln, being careful not to damage the brick or the thermocouple.

STEP 3

- Remove the cardboard and peep plugs attached to the stand.

STEP 4

- Install the black plastic stand feet which are located in the plastic bag with the manual.

STEP 5

- Place the stand where the kiln will be located. If you have an older style EnviroVent (where the fan motor mounts directly under the kiln), place it in the stand now.

PLACE SLAB (KILN BOTTOM)

STEP 1

- Undo the buckles that hold the kiln slab to the kiln. Lift the kiln off the slab and place on a clean flat surface. Be careful not to set the kiln on anything (watch the power cord), that will damage the bottom row of bricks.

STEP 2

- Center the slab on the stand. Allow a minimum of eighteen inches (46 cm) of spacing from walls and other kilns.

STEP 3

- If the stand is not level or wobbles, shim legs accordingly. Do not place shims between the stand and the slab.

PLACING THE KILN

STEP 1

- With a partner, pick the kiln up by the chest handles and rest it on top of the kiln slab (floor).

STEP 2

- On models with slabs that buckle to the kiln, reattach the buckles.

PLACE PEEP PLUGS

Place the white porcelain peep plugs into the peepholes of the kiln. Give them a slight twist to lock them in. If you are not using an EnviroVent, EnviroVent 2, or any other Downdraft vent, be sure to leave the top peep plug out when firing.



CLEAN

Vacuum the inside of the kiln to remove dust, brick chips, and other foreign matter from around the elements. Be sure not to get the hose too close to the touch pad. Static electricity built up in the hose can damage the electronics.



KILN WASH SHELVES

Brush coat one side of each shelf with high fire kiln wash. Apply a thin coat of kiln wash in one direction, allow to dry, and apply another thin coating in the opposite direction leaving a half inch (1.3 cm) margin from the outside edge of the shelf. Allow to dry overnight. **Never kiln wash the walls or lid of your kiln!**



TEST FIRING

The test fire is very important and should not be skipped. It accomplishes several objectives

- Ensures the kiln is operating correctly and nothing was damaged in shipping.
- Burns off element oils and develops an oxide coating which will help prolong the life of the elements.

LOADING

This first firing should be done with only kiln shelves. Place the first shelf layer on one-inch (2.5 cm) posts above the slab. When loading ware in the kiln, it is important to load it evenly to ensure proper ventilation. For a full description on loading, see Appendix 4 — Loading Tips.

PLACE WITNESS CONES

A Cone 04 (1945°F/1063°C) is recommended for proper pre-oxidation of a new element. For more about cones, see Appendix 3 — Heat Work (Cones). If your kiln is equipped with a lid lifter, be sure to latch the lid shut.

TEST FIRE THE KILN

Follow the Cone Fire Mode programming instructions found in the Programming section of this manual to run a **Cone 04**, **Medium Speed** program with **No Hold** time and **No Preheat**. After the kiln has cooled to room temperature, unload the kiln and inspect the cones. If the Cones are satisfactory you are ready to begin using the kiln. If there is a problem with the cones see the section on fine tuning your kiln on page 13.

GENERAL PROGRAMMING INFORMATION

THE LED DISPLAY

The display, while improved, is still limited to 4 characters and 14 segments per character. This is not always enough to exactly represent the message presented. If you find you do not understand a message, consult the Display Messages section of this manual.

The controller may be programmed in either Celsius or Fahrenheit. It is very important to know which temperature scale it is using. If there is a LED illuminated in the lower right hand corner of the display, the temperature scale is set to Celsius. Refer to the MENU section of this manual to change scales if necessary.

When prompted to enter time values, there will be an LED illuminated in the lower center portion of the display. We refer to this as a decimal point. Everything to the left of the decimal will be hours and everything to the right will be minutes.

IDLE MODE

When the kiln is flashing IdLE alternately with the current temperature of the kiln chamber we refer to the controller as being in Idle Mode. This simply means that the kiln is ready to be programmed. To return to Idle mode you may press STOP at any time. If controller is programmed for Zone Control, the display will also show current thermocouple being read.

START/STOP/ENTER

The START key begins the program which is currently loaded in memory. It may only be accessed when the kiln is in Idle Mode. The STOP key will turn off the kiln at any point of a program. It may also be used to return to Idle Mode in the middle of entering a program. ENTER must be pressed after entering any time, temperature or programming speed. ENTER is also used to turn an Alarm off that has sounded during a firing.

DELAY

The Delay feature allows you to program, the kiln to automatically start at a future time. This feature is primarily used to take advantage of better off-peak electric rates or to time the shutoff of the kiln for a time that is convenient for you to be there. It can be set for a Ramp Hold Mode or Cone Fire Mode program and can be accessed only after the program has been entered and the controller is in Idle Mode. You can enter a delay time up to 99 hours and 99 minutes.

From Idle Mode, press **DELAY**
Input **Delay time in hours and minutes**, then press **ENTER**

When START is pressed to begin the program, the time entered for the delay will reappear on the screen and begin counting down. When it reaches 00.00 the kiln will start the program currently loaded. **The Delay time will stay in memory until it is cleared.** To clear it, follow the instructions for entering a Delay and enter 00.00 for the Delay time.

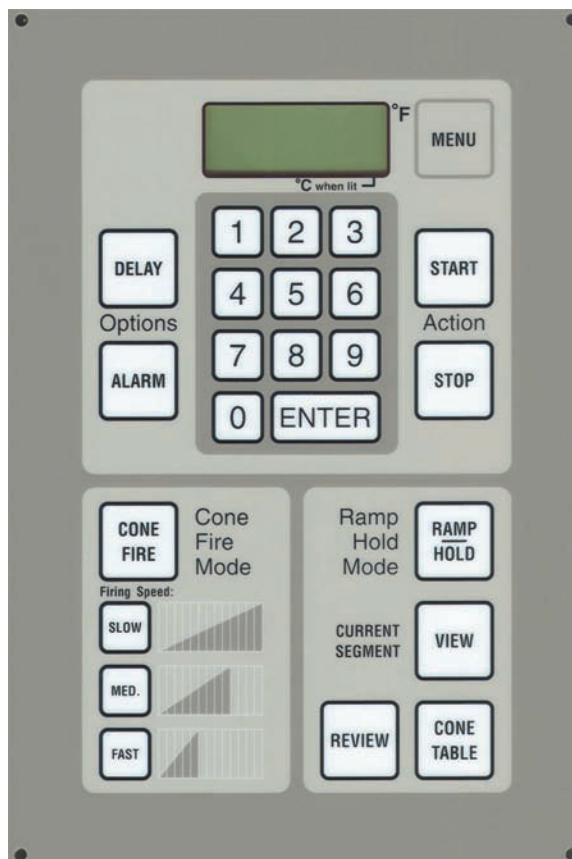

ALARM

The Alarm feature is used to sound an Alarm at a specific temperature in the program. This feature is primarily used to prompt the user to lower a propped lid or for glass artists to look into the kiln at peak temperature. It can be set for a Ramp Hold or Cone Fire program. You can enter any Alarm temperature between 0 and the maximum temperature rating of the kiln.

From Idle Mode, press **ALARM**
Input **Alarm Temperature**, then press **ENTER**

When START is pressed the program currently loaded will begin. When the temperature of the kiln reaches the Alarm temperature entered, the Alarm will sound in a series of beeps. **Press ENTER to turn off the Alarm. Do not press STOP, this will stop the program. The Alarm temperature will stay in memory until it is cleared.** To clear it, follow the instructions for entering an Alarm and enter 9999 for the Alarm Temperature. "9999" is the default for having the Alarm off.

MENU

The Menu features are discussed in depth in the Menu Features section of the manual.

REVIEW

The Review key allows the user to look at the current program loaded to make sure it is correct. We highly suggest to use this feature to check programs prior to each firing. Press **REVIEW** and the display will step through each segment of the program for a Ramp/Hold program. It will also let you know if there are Alarm temperatures or Delay times entered and whether or not the Error Codes feature is ON or OFF. Below is a sample Review of a Cone Fire program.

Sample Cone Fire Review

- | | | |
|---------|------|---|
| 1. Cone | 04 | Cone Number |
| 2. F | 1920 | Actual temperature when kiln shut off |
| 3. SPD | FAST | Cone fire speed |
| 4. HOLD | 0.00 | Length of hold at top temperature |
| 5. PRHT | 0.00 | Preheat time (Will only be displayed if preheat is set to ON) |
| 6. DELA | 0.00 | Delay Time |
| 7. ALRM | 9999 | Alarm Temperature |
| 8. ERCD | ON | Error Codes on or Off |

VIEW

The View key allows you to determine what segment of a Ramp/Hold program the controller is currently running. While a Ramp/Hold program is firing press **VIEW**. The display will show the current segment, the traveling set point, and the circuit board temperature. The segment number is prefixed by either "RA" (Rate) or "Hld" to indicate whether the kiln is heating (or cooling) or holding temperature. The traveling set-point indicates the target temperature of that segment.

CONE TABLE

The Cone Table key allows the user to look up the temperature equivalent of Cone values. To use simply press **Cone Table** from Idle Mode, enter a cone value and press ENTER. This key may also be used to insert a Cone Value for the peak temperature of a Ramp and Hold program. This Cone Value will be automatically adjusted (Cone Correlation) based on the performance of the kiln. To use this feature press Cone Table when prompted to enter the peak temperature of your program, enter a Cone value and press Enter.

DURING THE FIRING

You will see the internal temperature of the kiln displayed as the temperature increases. The options available during the firing are:

- Review program at any time.
- View Current Segment of **RAMP/HOLD** Program.
- Press **STOP** to interrupt a firing for any reason.

Note it is common to see smoke come out of your kiln on the first firing. This is normal; the elements are burning off their protective coating.

AFTER THE FIRING

- When completed, the display will show "CPLt" alternately with the firing time in hours and minutes and the current temperature of the kiln. Press **ENTER** to return to Idle Mode.
- When a Cone Fire Mode program (or a Ramp and Hold program which uses the Cone Correlation feature) is run, the controller may alter the peak temperature of the program based on the kiln's ability to achieve the final temperature rate. This is done to insure the heatwork remains constant. If you are interested in knowing if that temperature changed, press **REVIEW** after the program is complete. This temperature value will only appear in a review once after the firing so be sure to pay attention.
- Allow the kiln to cool naturally. Never unplug additional peepholes or post the lid until the ware is cool enough for barehanded unloading, about 130°F (54°C).
- When unloading, be sure to examine the Self-Supporting Cones on the shelf to determine if the kiln is firing correctly.
- It is not necessary to unplug the kiln when not in use (unless severe storms are expected). Continuous plugging and unplugging may cause components in the plug and receptacle to loosen up over time. Loose components in electrical connections create heat and can pose a fire hazard.

FINE TUNING YOUR KILN

If after inspecting your witness cones you find that the kiln fired a little hot, a little cold, or a little uneven, there are certain things you can do to fine tune the kiln before your next firing. Always be sure you use Self Supporting 108°F (42°C) Witness Cones. Cones should be placed about 2 inches (4.8 cm) from the kiln wall and or thermocouple. Never place cones directly on the bottom slab.

Too Cool

Add more Hold Time to a Cone Fire program. If the target cone did not bend at all, try adding 15 minutes to the Hold Time. If the Cone has started to bend, add time in 5 minute increments. If hold times begin exceeding 30 minutes contact Skutt or your distributor for more information.

Too Hot

If the Cone is knuckled down on the shelf, reduce the Hold Time by 15 minutes. If the tip of the Cone has just started to touch the shelf, reduce Hold Time in 5 minute increments. If hold times are already set to zero, contact Skutt or your distributor for more information. Thermocouples drift towards an over fire as they age so if the problem persists or requires excessive changes to correct, it may be time to change the thermocouple.

Uneven Heat Distribution

Kilns will tend to fire cooler on the top and the bottom. Skutt compensates for this effect by putting hotter elements in these spots. If you notice a certain area consistently firing cooler, load those areas a little less dense. If areas are firing a little hot, load them a little more dense. Always be sure to post the first shelf at least 1" (2.5 cm) above the slab and if you have a small load, concentrate the mass towards the center of the kiln.

Downdraft vents such as the EnviroVent 2 help with uneven heating by mixing the air within the kiln chamber.

CHOOSING A PROGRAMMING MODE

The first step in programming your kiln is to decide which "Programming Mode" to use. Before making this decision it helps to have a good understanding of Firing Programs. A Firing Program consists of a series of program segments. Each segment consists of a Rate, a Temperature and a Hold Time. These segments determine the rate at which the kiln will heat up or cool down and how much Heatwork the pieces in the kiln will receive. For more information on Heatwork see Appendix 3.

CONE FIRE MODE

With Cone Fire Mode the programs are written for you. You simply give the controller some key information regarding the pieces you are firing and it accesses a program which best suits your project. This is the most commonly used mode of programming. The programs were created by Ceramic Engineers and are designed to minimize problems that can occur during critical stages in the firing process.

Cone Fire Mode is incredibly easy to use however, the software itself is extremely advanced. Cone Fire Mode uses complex algorithms to simulate the heatwork of a Pyrometric Cone. What is impressive is that it automatically makes adjustments to the firing profile based on your kilns performance. Cone values are based on heatwork and heatwork is a function of time and temperature. Therefore, if your kiln is firing slow due to a heavy load or aging elements, Cone Fire Mode automatically adjusts the peak temperature down so you get the perfect amount of heatwork. There are very few reasons not to use this mode of programming.

RAMP/HOLD MODE

RAMP/HOLD Mode allows you to write your own programs when the results you want cannot be achieved through Cone Fire Mode. It is a perfect tool for:

- Fusing and slumping glass
- Annealing metal and glass
- Firing Precious Metals
- Clay
- Specialized glaze formulations and techniques

Ramp/Hold is generally considered an advanced form of programming. It requires in-depth knowledge of heatwork and a good feel for how your kiln performs under a range of conditions. Below is an example of a simple glass fusing Ramp/Hold program.

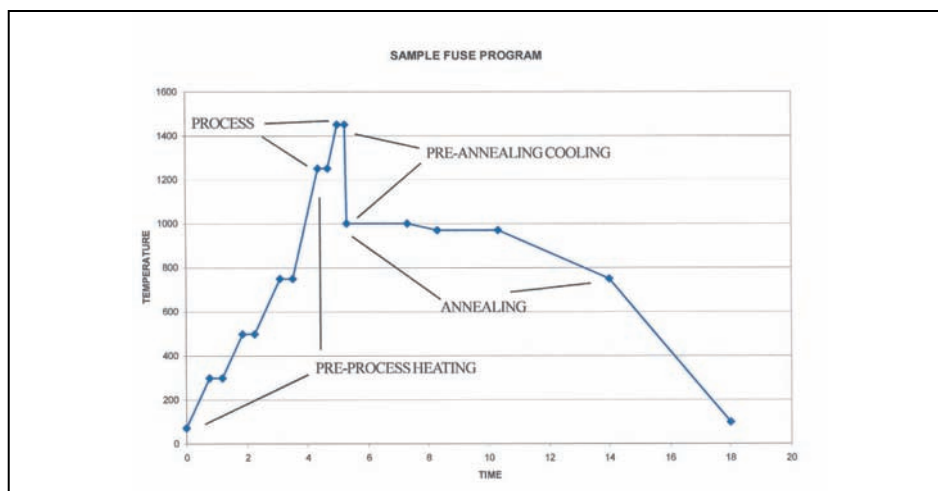

PROGRAMMING CONE FIRE MODE

PROGRAMMING STEPS

STEP 1

- From Idle Mode. Press **CONE FIRE**.

Display will read PRHT alternately with 00.00.

STEP 2

- Input a **PREHEAT TIME IN HOURS AND MINUTES**. Press **ENTER**. (See page 23 for more information on Preheat.)

Display will read CONE alternately with the last Cone Value entered.

STEP 3

- Input a **CONE VALUE**. Press **ENTER**.

Display will read Spd alternately with the last Speed entered.

STEP 4

- Press a **SPEED (SLOW, MED or FAST)**. Press **ENTER**.

Display will read HOLD alternately with a Hold time value.

STEP 5

- Input a **HOLD TIME** if one is desired. Press **ENTER**.

Display will flash CPL, then will return to Idle Mode. At this point the program is loaded and ready to start. Before pressing START, it is a good idea to press REVIEW to make sure the program was input correctly. Also, verify that the lid latch is engaged if your kiln is equipped with a lid lifter and check to see the area is clear of all combustible materials.

STEP 6

- Prepare **Venting**.

If your kiln is equipped with and EnviroVent2 you will want to turn it on before pressing start. Be sure the lid is closed (and latched if you have a Lid Lifter) and all the Peep Plugs are in. If your kiln is not equipped with a vent system you will want to prop the lid open until the chamber temperature reaches 1000 °F (538°C). If your kiln is equipped with a Lid Lifter, use the installed Lid Prop. If your kiln does not have a built in Lid Prop, use a wedge of firebrick to prop it approximately 1 to 2 inches. Always use a fire proof glove to remove your prop.

STEP 7

- Press **START**.

Display will read -ON- briefly and then display the current temperature of the kiln. If a delay start has been entered the display will begin counting down the time entered.

When the firing is complete the display will read *CPLT* alternately with the current temperature of the kiln and the time it took to complete the program. To clear this data and return to Idle Mode and press **ENTER**.

DESCRIPTION

STEP 1 - CONE FIRE

The Cone Fire Mode runs a factory installed multi-segment program which is selected based on the Cone Value, Speed, and Hold time you choose. To the right is an example of a program which is run if you choose a Cone Value of 04, a Speed of Medium and Hold time of 5 minutes.

One of the greatest features of Cone Fire Mode is Cone Correlation. It automatically measures the rate of firing during the last hour of the heating program and adjusts the final temperature based on the observed firing rate. This will insure consistent results as the kiln elements become weaker with normal wear from repeated firing. As a result the shutoff temperature may vary between firings.

SEGS	RATE	TEMP	HOLD
1	200 °F/HR	250 °F	0
2	400 °F/HR	1000 °F	0
3	180 °F/HR	1150 °F	0
4	300 °F/HR	1694 °F	0
5	120 °F/HR	1946 °F	00.05

STEP 2 - PREHEAT

Preheat is used to preheat the ware inside of the kiln before the temperature goes above the point when water turns to vapor. If residual water in the clay escapes as vapor too fast it can crack the ware or in extreme cases cause it to explode. Large, thick walled, pieces are more susceptible to damage caused by residual moisture.

When a Preheat time is entered and the program is started the kiln will climb in temperature at a rate of 60°F (15°C) per hour until it reaches 180°F (82 °C). It will then hold at that temperature for as long as the time entered. After the hold is complete, it will begin the Cone Fire program. If you do not wish to preheat your ware, enter 00.00 for the hold time. For instructions on turning this feature off, consult the Menu section of this manual.

STEP 3 - CONE VALUE

Every clay and glaze should have a Cone Value associated with it. A Cone Value is a measurement of the Heatwork needed for the clay or glaze to mature. The Heatwork is measured through the use of Pyrometric Cones (see pg 42.) The values of these cones used by the KilnMaster controller ranges from Cone 022 through Cone 10. It will not let you enter a cone value outside of this range. **Remember that there is a big difference between values with "0"s in front of them and ones without "0"s. Example: A Cone Value of "6" is much hotter than a cone value of "06".**

STEP 4 - SPEED

The Firing Speed you select will determine how long the kiln will take to heat up. This is important because if you heat some pieces too quickly, they can crack or explode. There are three available speeds to choose from. Below is a description of each speed along with a graph showing the firing profile.

CONE FIRE – SLOW

Slow Speed will take approximately 12 hours to complete. Slow Speed is recommended for large or thick walled pieces. We recommend that most teachers use Slow Speed because it is often hard to tell how thick the walls are in a student's project. If you are unsure if the piece is completely dry, use this speed.

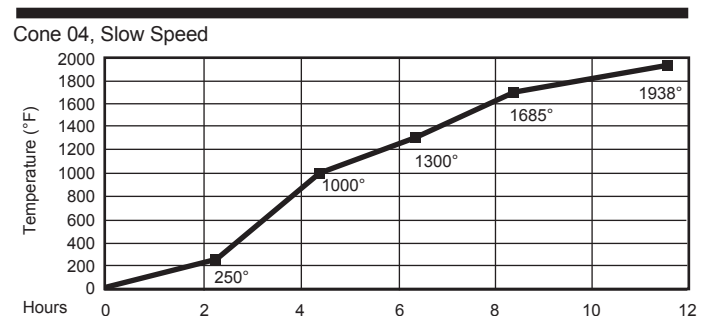

CONE FIRE – MEDIUM

Medium Speed will take approximately 7.5 hours to fire. Medium Speed is fine for most firings. When in doubt, use the Slow Speed

CONE FIRE – FAST

Fast Speed will take approximately 4 hours. This speed is only recommended for items such as lusters and decals which can handle the fast increase in temperature.

STEP 5 – HOLD TIME

HOLD is another important feature of CONE FIRE MODE. Once the kiln has achieved its peak firing temperature, HOLD can maintain that temperature for a set amount of time. This allows the user to make fine tune adjustments to the firing process by introducing more heatwork which can help witness cones reach maturity. Additionally, a HOLD permits the kiln to equalize temperature, allowing for even firings and firings that fall between cone temperatures, for example cone 05.5.

CAUTION: Excessive hold time can result in over firings. A common mistake is to enter ten hours when a ten-minute hold is desired. 00.10 equals ten minutes, 10.00 equals ten hours.

STEP 6 – PREPARE VENTING - (SEE DESCRIPTION ON PAGE 15)**STEP 7 – START**

Start initiates the CONE FIRE MODE firing program. If a Delay is entered the kiln will start a countdown from the amount of entered delay time. Before pressing START, verify that the lid latch is engaged, and that all combustible materials are moved out of the vicinity

ADVANCED CONE FIRE MENU FEATURES

In Cone Fire mode, the operator has the ability to modify the firing program. They can do this in one of two ways. The first method allows the user to program custom Cone Fire programs. The second involves controlling the rate in which the kiln cools down

WRITING CUSTOM CONE FIRE PROGRAMS

This new feature on the 700 Board allows you to utilize the cone correlation benefits of Cone Fire Mode coupled with the flexibility of RAMP/HOLD Mode. To use Cone Correlation to calculate your final temperature during a RAMP/HOLD program press **CONE TABLE** instead of entering a temperature for your final heating segment. Input the Cone Value you would like to correlate and Press **ENTER**.

SLOW COOLING (CONE FIRE CONTROLLED COOLING)

COOL is a feature that allows you to add a 1-segment cooling program to the end of a Cone Fire program. When COOL is toggled "ON" it will prompt you to enter a "Rate", "Temperature", and "Hold Time" after you finish entering the Hold Time for a Cone Fire program. This is helpful when trying to achieve certain glaze effects.

Cone 04, Medium Speed

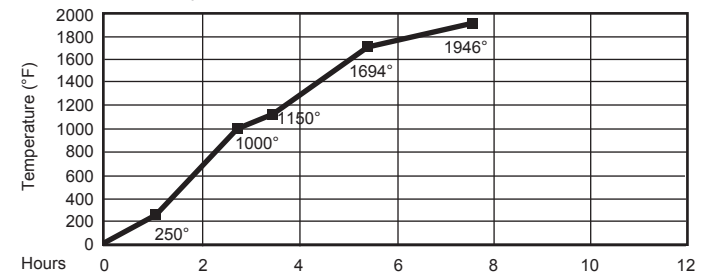

Cone 04, Fast Speed

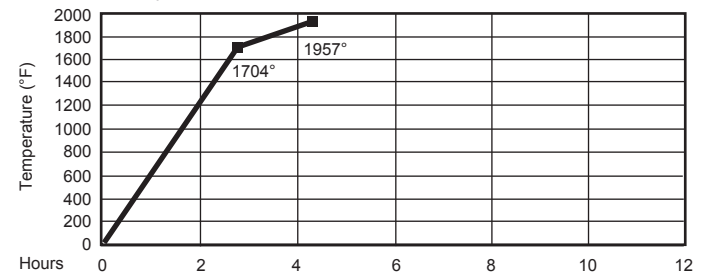

PROGRAMMING THE RAMP/HOLD MODE

PROGRAMMING STEPS

STEP 1

- From Idle Mode, press **RAMP/HOLD**.
Display will show PROG alternating with a number between 1 and 6.

STEP 2

- Input the **PROG Number** of the Program you wish to create or run. *(This is a number between 1 and 6 that you assign to a program which will be stored in permanent memory until it is replaced.)* Press **ENTER**
Display will show SEGS

STEP 3

- Input the total number of segments for your program. Press **ENTER**.
Display will show RA 1

STEP 4

- INPUT THE FIRST HEATING RATE IN DEGREES PER HOUR. PRESS **ENTER**.
Display will show °F 1 (or °C 1 if using Celsius)

STEP 5

- INPUT THE FIRST TEMPERATURE TO REACH. PRESS **ENTER**.
Display will show HLD 1.

STEP 6

- INPUT THE AMOUNT OF **Hold Time** in hours and minutes. Press **ENTER**.
Display will show ALRM if this the last segment you are entering, otherwise it will show RA 2.

STEP 7

- **REPEAT** steps 4 through 6 until all segments have been completed. The display will then flash **ALRM** (Alarm) alternately with the current Alarm temperature. The default setting for no alarm is 9999. Enter the desired alarm setting. Press **ENTER**
Display will briefly flash CPL

STEP 8 – PREPARE VENTING - (SEE DESCRIPTION ON PAGE 15)

STEP 9

- The display will return to Idle mode. At this point the program is loaded and ready to start. Before pressing **START**, it is a good idea to press **REVIEW** to make sure the program was input correctly. Be sure to check that the lid latch is secure on kilns that are equipped with lid lifters. **Press START** and the program will begin firing.
Display will briefly show ON and then will show the internal temperature of the kiln chamber unless a DELAY START has been programmed in which case it will begin counting down minutes from the designated Delay time.

DESCRIPTION

STEP 1 – RAMP/HOLD

RAMP/HOLD MODE IS A MODE OF PROGRAMMING THAT ALLOWS YOU TO WRITE YOUR OWN FIRING PROGRAM. WHEN YOU ARE ENTERING YOUR PROGRAM YOU WILL NOTICE DATA ALREADY STORED. SIMPLY WRITE OVER THIS INFORMATION. IF YOU MIS-ENTER DATA YOU MAY EITHER PRESS ZEROS TO CLEAR THE DATA AND RE-ENTER IT OR PRESS STOP TO START FROM THE BEGINNING.

STEP 2 – PROGRAM NUMBER (PROG)

You have the option of storing up to six firing programs. You may recall these programs at any time for future use. We recommend that you write down which number you have assigned each program so that you do not overwrite existing programs you have stored.

STEP 3 - SEGMENTS (SEGS)

This step is prompting you to input the total number of segments you wish to use in your program. Each segment consists of a heating or cooling rate, a target temperature, and a hold time at that target temperature if one is desired. You may program up to eight segments. Two programs may be connected to achieve 16 segment programs. See instructions on page 20.

STEP 4 – RATE (RA#)

This step is prompting you to input a Temperature Rate. The display will show RA along with the current segment number you are programming alternately with the previous data entered. You may enter any rate between 1 °F/hr (1 °C/hr) to 9999 °F/hr (9999 °C/hr). This can be a cooling rate or a heating rate. The controller distinguishes between the two by checking to see if the temperature entered in the next segment is hotter or cooler than the previous segment.

Just because you enter a rate does not mean the kiln is capable of achieving that rate. Things such as element age, load density, and temperature range will all affect the kiln's ability to heat. Conversely, the kiln's insulation will influence its ability to cool. A rate must be entered for each segment.

STEP 5 – TEMPERATURE (°F#) OR (°C#)

This prompt is asking you to enter a temperature to go to. When it gets to that temperature it will either hold at that temperature or switch to a new rate and aim for a new temperature. If you are programming in Celsius it will read °C instead of °F. The controller will allow you to program temperatures between 32 °F (0 °C) and 2400 °F (1315 °C). A temperature should not be entered which exceeds the kiln's temperature rating.

STEP 6 – HOLD TIME (HOLD)

A HOLD time is generally entered to allow the kiln time to balance out and all of the pieces in the kiln to reach the input temperature before the kiln moves to the next segment. You may enter hold times of 00.00 to 99.99.

A Hold at peak temperature can be used for this reason or to gain additional heatwork to fine tune cone bends or to fire in-between cones. Remember that everything to the left of the decimal point on the display is Hours and everything to the right is Minutes. Excessive Hold times may cause over-fires.

STEP 7 – REPEAT

Continue to enter a rate, a temperature and a hold time for all the segments. When the last segment has been entered the display will prompt you to enter an Alarm temperature. The default is 9999 for no alarm. Input an Alarm temperature and Press **ENTER**. The display will briefly flash CPL for "complete" and then return to Idle Mode. The program is now loaded.

STEPS 8 AND 9 – PREPARE VENTING AND START

Before starting the program it is always a good idea to press **REVIEW** and make sure the data was entered correctly. If you find an error simply press **RAMP/HOLD** and continue to Press **ENTER** until you find the error and are able to correct it. If there is a Delay entered, when you press start the kiln will begin counting down from the input time. Remember to turn on your vent (or prop your lid) before pressing **START**

ADVANCED FEATURES

16-SEGMENT

When the 16-Segment feature is toggled ON, the controller links programs #5 and #6. Now, when you run program # 5, it will automatically run program #6 to continue the firing after program #5 has completed. Due to requirements of the software, the first segment of Program #6 must be increasing in temperature. Here is how to use this feature:

STEP 1

- Input a 1 to 8 segment RAMP/HOLD Program in PROG #5.

STEP 2

- Input a 1 to 8 segment RAMP/HOLD Program in PROG #6.

STEP 3

- Press **RAMP/HOLD**, Press **5**. Press **ENTER**. Press **STOP**

STEP 4

- Press **MENU**. The Display will show SET. Press **ENTER**. The Display will show PRHT. Press **MENU** until the display shows 16-S then press **ENTER**. The display will show OFF. Toggle to ON using the **1** key, then press **ENTER**

STEP 5

- Press **REVIEW**. Press **START**

IMPORTANT. Program #5 must be cued prior to toggling the feature, **ON**. Once both programs have run, the controller automatically toggles **OFF** the 16-segment feature.

SKIP STEP

Skip any segment in a Ramp/Hold Program by pressing **VIEW** quickly followed by pressing **ENTER**. If done quick enough you will see SKIP in the display. Immediately press **ENTER** again

CONE CORRELATION

The 700 Board allows you to utilize the cone correlation benefits of **CONE FIRE Mode** coupled with the flexibility of **RAMP/HOLD MODE**. To use Cone Correlation to calculate your final temperature during a **RAMP/HOLD** program, press **CONE TABLE** instead of entering a temperature for your final heating segment. Input the Cone Value you would like to correlate and press **ENTER**.

RUNNING A STORED RAMP HOLD PROGRAM

STEP 1

- Press **RAMP/HOLD**.

Step 2

- INPUT DESIRED STORED PROGRAM NUMBER

STEP 3

- Press **STOP**

STEP 4

- Press **REVIEW**

STEP 5

- Press **START**

KILN MASTER MENU TREE

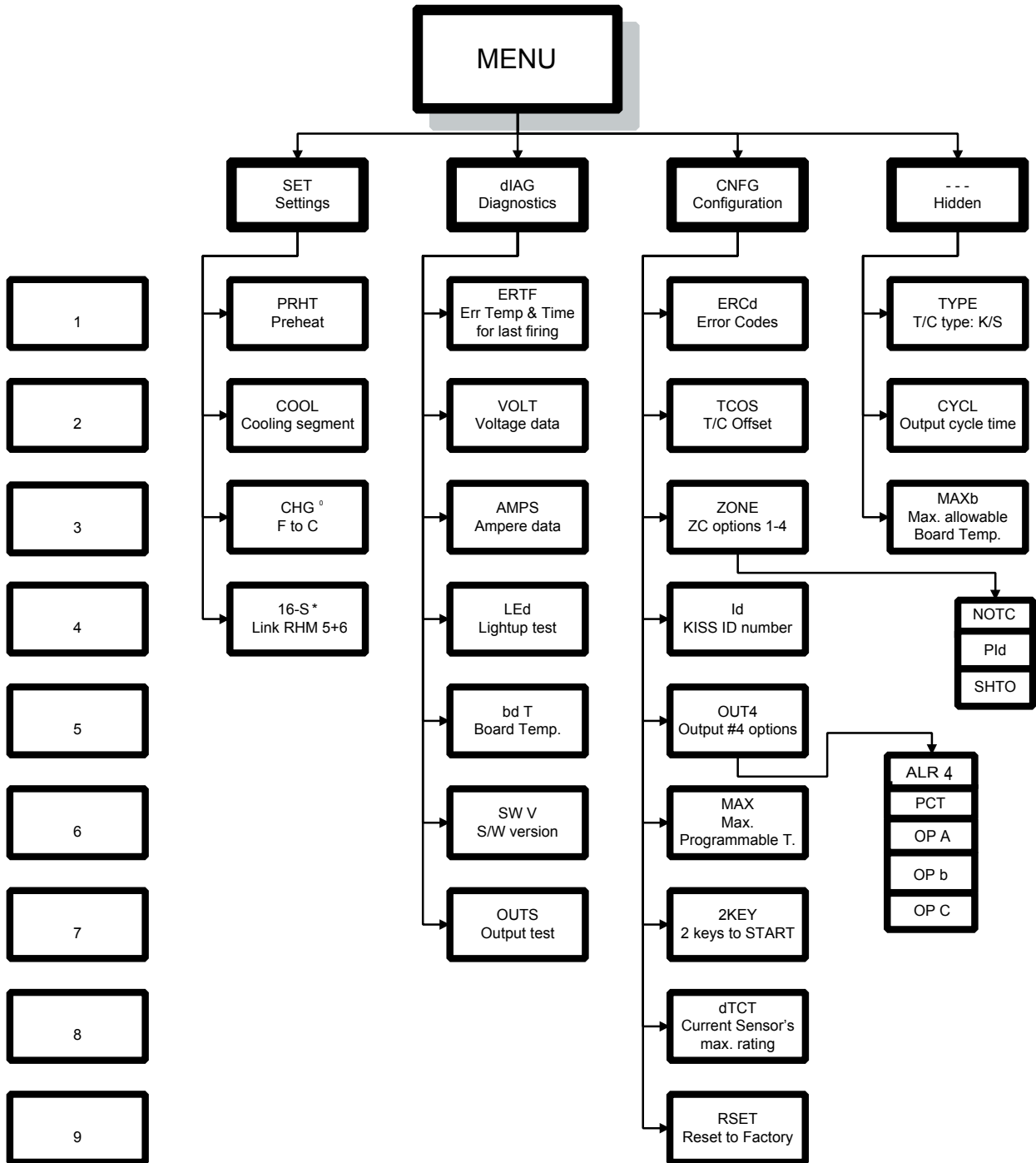

* - Only available when Ramp/Hold Program #5 is "active".

NEW FEATURES

Among other changes, the New KilnMaster 700 Board has the ability to do self-diagnostics. It can now show the voltage and amperage directly from the display, eliminating the need for expensive test equipment or having to hire a technician. Look through the entire MENU selection to become familiar with the options available to you.

NEW MENU LAYOUT

With the exception of the new green 14-segment LED display, you will notice that the board and all of the function keys look exactly the same. All of the changes have been made in the **MENU** key.

There are now four option headings under the **MENU** key. They are:

- SET Settings
- DIAG Diagnostics
- CNFG Configurations
- Other 

MENU PROGRAMMING TIPS

To access the Menu Headings, press **MENU**.

You can toggle through the Menu Headings by continuing to press the **MENU** key. When you reach the one you wish to access press **ENTER**. This will take you to the first option in that submenu. As before, if you want to toggle through the various options under the selected Heading, press **MENU**. When you reach the option you wish to access, press **ENTER**.

When you select an option, you are asked to either:

- Toggle the option **ON/OFF**
- Input a value
- Choose a value

To toggle options **ON/OFF**, press **1**. When you get to the desired setting, press **ENTER**.

To Input a value such as a Delay time or an Alarm temperature, input the value and press **ENTER**.

To select a value, press the **MENU** key until your selection is displayed, and then press **ENTER**.

PROGRAMMING INSTRUCTIONS

SET (SETTINGS)

SET, is where all of the commonly used options are located. The following options are available under the SET heading menu:

- **PRHT (PREHEAT)**

This feature allows you to toggle the Preheat feature ON or OFF. The Preheat feature allows you to Input an amount of time to hold at 180°F (82°C) prior to running a CONE FIRE Program. This feature is recommended when firing large, thick-walled, or potentially damp ware. When the feature is toggled ON, it will prompt you to input a hold time value after the CONE FIRE key is pressed.

- **COOL (CONE FIRE CONTROLLED COOLING)**

This feature allows you to add a 1-segment cooling program to the end of a CONE FIRE program. When it is toggled "ON", it will prompt you to input a "Rate", "Temperature", and "Hold Time" after you input the Hold Time for a CONE FIRE program. This is helpful when trying to achieve certain glaze effects.

- **CHG ° (CHANGE FROM FAHRENHEIT TO CELSIUS SCALE)**

The controller can display temperature values in Fahrenheit or Celsius. If the scale is set to display in Celsius an LED dot will illuminate in the bottom right hand corner of the display. To select a new scale, press **ENTER**, and it will automatically toggle to the alternate scale. " °C " represents Celsius and " °F " represents Fahrenheit.

- **16-S (16-SEGMENT)**

This option links the RAMP/HOLD programs stored in memory positions 5 and 6 to create a 16-segment program. Normally a program is limited to 8 segments. This feature will only display when a CONE FIRE Mode program or the number 5 Ramp/Hold program is loaded. See page 20 for programming instructions.

DIAG (DIAGNOSTICS)

"DIAG" or Diagnostics, is where all of the diagnostic tools are located. The following options are available under the "DIAG" menu:

- **ERTF (ERR TEMP & TIME OF LAST FIRING)**

This feature will display the temperature and the point of time in the firing at which the last Error occurred. Often times this information is helpful in troubleshooting the problem which created the error. Once "ERTF" is selected, it will first flash the temperature at which the error occurred and then the time into the firing it occurred. The ERTF information will also appear automatically when an error alarm sounds and the program is terminated. Pressing any key, will show the temperature and elapsed time at which the error occurred.

- **VOLT (VOLTAGE)**

This feature is used to test the voltage supply to your kiln. It tests the voltage first with the elements off, "No Load" and then again with the kiln on, or "Full Load". Select "VOLT" from the "DIAG" menu and press **ENTER**. After the "NOLd" reading is displayed, press **ENTER** to receive the "FLLd" reading. The power to the kiln will be switched on for a brief moment when the voltage under load is checked. Our technicians can use this information to help you troubleshoot voltage related problems over the phone. When the voltage readings appear on your display, write them down. Often times voltage related problems can happen only at certain times of day, so try to obtain the readings at the same general time your kiln would be firing.

- **AMPS (AMPERES)**

This is probably the most useful diagnostic tool available to you. All KilnMaster kilns produced after 3/20/2006 are equipped with a current sensor in the control box. This allows us to test the current of each output to the kiln. This is very helpful in determining if a relay or element needs replacing.

When you select "AMPS" under the "DIAG" menu, it will give you an ampere reading for each output of the kiln (except the accessory and safety output). Which elements these outputs control will vary by model. If your kiln uses only one or two outputs it will still give you three readings but the unused outputs will give a reading of zero.

- **LEd (LED Display)**

This feature, when activated, lights up all of the segments in the LED display. This is helpful in locating any segments in the display that may have gone bad and may explain why some indicated readings are not correct.

- **bd T (Board Temperature)**

The electronics on the controller's circuit board may be damaged if the board exceeds 160°F (71°C). This should not occur under normal conditions. However, if the kiln is located in a small enclosure with poor ventilation or in areas where the temperatures are unusually hot, it is possible. Using this feature will tell you if your controller temperature is approaching potentially harmful levels.

If you find that your board temperature is consistently over 150°F (65°C), you may want to consider improving air circulation to the kiln room. A box fan blowing on the controller can help considerably.

- **SW V (SOFTWARE VERSION)**

At Skutt, we are continually working on ways of improving our products. This feature will indicate the software version your controller is using.

- **OUTS (OUTPUT TEST)**

There are four outputs that can be used on the board. There are three designated for elements and one designated to run an accessory. This feature allows you to test each output individually to see if it is operating correctly.

When activated this feature will test each output beginning with Output 1 and ending with Output 4. It will cycle each output on for approximately two minutes. You can advance to the next output at any time by pressing **ENTER**. To see if the elements are cycling ON, you can place a small piece of paper on each element. If the paper is burned, then the element came on.

Be sure that the control box and kiln lid are closed before you use this feature in order to **avoid electrical shock**

CNFG (CONFIGURATION)

CAUTION: Be sure to consult with a Skutt technician before making any configuration setting changes. Unadvised changes can cause permanent damage to your kiln and the ware inside it.

"CNFG" or Configuration, is where all of the controller configuration tools are located. The following options are available under the "CNFG" menu:

ERCd (Error Codes ON/OFF)

Error codes are designed to help protect you, your kiln, and your ware when something goes wrong with the firing. There are times however, where you may wish to try a new technique which would trigger an error code under normal conditions. When error codes are turned off, the following codes are disabled:

- Error 1 - Terminate firing when kiln temperature increasing at a rate slower than 12°F (11°C)/hr.
- Error 2 - Kiln Temperature 50°F (10°C) degrees above hold temperature.
- Error 3 - Kiln Temperature 50°F (10°C) degrees above hold temperature.
- Error 4 - Kiln Temperature 50°F (10°C) degrees above previous hold when ramping down.
- Error 5 - Kiln Temperature 50°F (10°C) degrees below traveling set point when ramping down.
- Error D - Kiln Temperature 50°F (10°C) degrees above traveling set point

• TCOS (THERMOCOUPLE OFFSET)

This feature allows you to calibrate the thermocouple when it is reading consistently and predictably incorrect. It is extremely important to consult with a Skutt technician before making thermocouple offset adjustments. Incorrect adjustments to the thermocouple offset can cause permanent damage to your kiln. Adjustments made to the thermocouple offset will affect all **RAMP/HOLD** and **CONE FIRE** programs.

If you are experiencing problems with CONE FIRE Mode, check to see if the ending temperature and hold time of the programs you are running have not been significantly altered from the factory programs before making thermocouple offset adjustments.

Access the TCOS setting through the CNFG menu. The display will flash °FOS alternately with the current offset setting. °FOS represents degrees Fahrenheit Offset. If the controller was programmed to display in Celsius, the "F" would be replaced by a "C". If there is currently an offset input, this could be the problem. To be safe, make adjustments in small increments and then run a test fire with Self-Supporting Cones.

• To MAKE THE KILN FIRE COOLER

STEP 1

- Input **00** followed by the number of degrees you wish to offset the thermocouple.

Step 2

- Press **ENTER**
Ex: "0010" makes the kiln fire 10 degrees Cooler.

• To MAKE THE KILN FIRE HOTTER

STEP 1

- Input **90** followed by the number of degrees you wish to offset the thermocouple.

Step 2

- Press **ENTER**
Ex: "9010" makes the kiln fire 10 degrees Hotter.

- **ZONE (ZONE CONTROL OPTIONS)**

Zone control is a feature that comes standard on the Production line of KilnMaster kilns. This line includes the following models PK1227 and PK 1627. Zone Control is feature that allows the controller to independently fire sections on multiple section kilns to ensure even temperature top to bottom.

There are three optional setting configurations for Zone Control which can be accessed through the "ZONE" feature under the "CNFG" menu

- NOTC
- Pld
- SHTO

- **NOTC (NUMBER OF THERMOCOUPLES)**

Your kiln should be properly programmed for the correct number of thermocouples before it leaves the factory. All KilnMaster kilns will be set at 1 thermocouple except the KM1627 which comes standard with Zone Control. You cannot set a kiln to fire in more than one zone unless it is configured in the factory as a Zone Control kiln. If you try you will receive a "FAIL" error code.

To change the number of zones on a zone control kiln access the "ZONE" setting through the "CNFG" menu then use the menu key to toggle to the "NOTC" feature and Press **ENTER**. The controller will display the current "NOTC" setting. Input the desired value and press **ENTER**.

- **Pld (Proportional Integral Derivative)**

PID is a zone control setting that uses the center section elements to help the bottom and top sections when necessary. In most kilns the center section is usually the hottest section. The PID option is designed to help speed up the firing when the top or bottom section is cooler and lagging behind the other sections.

When the top or bottom section is on full power (it is lagging behind), then output 2 comes on as a percentage of output 1 or output 3. The middle section will fire hotter and help the top and or bottom section catch up. The percentage can be set from 0 (zero) to 150. It is factory preset at 85%.

- **SHTO (SHUTOFF)**

Shut off is a zone control feature that attempts to make firings more consistent. For 2 and 3 zone controllers, when shutoff is OFF the controller uses the average of all three thermocouples to transition from one segment to the next or to shut off the kiln. When "on" the kiln turns off, or transitions, when any one of the thermocouples reaches temperature. FOR ALL DOWN RAMPS, the controller transitions from one segment to the next as if shut off "SHTO" were turned ON, i.e., when any one section reaches the next segment temperature.

- **Id (Control Interface System ID)**

CIS is an optional accessory that allows you to program and monitor multiple kilns from a PC. Each kiln hooked up to the CIS system needs to be identified with a unique number so the software can distinguish it from the other kilns. To set the identifying CIS number for each kiln access the "Id" setting through the "CNFG" menu, select a number between 1 and 99 and press **ENTER**

- **OUT4 (OUTPUT 4 SETTINGS)**

There are three standard outputs, one safety output and one accessory output on your Skutt KilnMaster controller. The accessory output is designated as Output 4 and can control a number of optional accessories including vents, alarms and autodialers. Output 4 will cycle these accessories on and off at different times depending on the program you are running and the way you configure it under the "OUT4" feature setting. There are five different options for OUT4.

NOTE: "ALR4" is the factory default setting. When you access the Output 4 feature the feature options will appear in the order listed below. The first option listed is not necessarily the current setting.

- **ALR4 (ALARM 4)**

This is the factory default setting. If Output 4 is not being utilized this is the setting that should be selected. This feature can also control an external alarm or autodialer to initiate if an Error Code is generated or if the internal temperature of the kiln reaches the temperature programmed for the **ALARM** setting of the program. To deactivate the alarm press **ENTER**

- **PCT (PERCENT ON)**

Output 4 can be programmed to be on for a percent of the time output 2 is on. This option is used when output 4 controls floor or lid elements. To ensure output 4 stays off at all times, use this option and set the percentage to zero. The percent can be set from 0 to 150. There are currently no Skutt Kiln designs that can utilize this feature.

- **OP A (OPTION A)**

When option A is selected Output 4 will turn on when a CONE FIRE Mode program is started. When the program has run and the kiln has cooled to 150°F (65°C), output 4 will turn off.

When a RAMP/HOLD program is inputted it will ask whether you want the fan (or other accessory) on for each segment you program. After you Input the hold time for each segment the display will show "FAN" along with the number of the segment you are programming. Alternately it will flash the current setting, either "OFF" or "ON". To change the setting toggle it with the **1** key and press **ENTER** to select that setting.

- **OP b (Option B)**

DURING A CONE FIRE PROGRAM OUTPUT 4 WILL TURN ON WHEN **START** is pressed. It will then turn off at 1450°F (788°C). It will turn back on when the kiln is cooling and the temperature drops below 1000°F (538°C). It will then turn off when the kiln cools to 150°F (65°C).

When a RAMP/HOLD program is inputted it will ask whether you want the fan (or other accessory) on for each segment you program. After you **Input** the hold time for each segment the display will show "FAN" along with the number of the segment you are programming. Alternately it will flash the current setting, either "OFF" or "ON". To change the setting toggle it with the **1** key and Press **ENTER** to select that setting.

- **OP C (OPTION C)**

When Option C is selected Output 4 does not come on during any portion of a CONE FIRE Mode program.

When a RAMP/HOLD program is inputted it will ask whether you want the fan (or other accessory) on for each segment you program. After you **Input** the hold time for each segment the display will show "FAN" along with the number of the segment you are programming. Alternately it will flash the current setting, either "OFF" or "ON". To change the setting toggle it with the "1" key and Press **ENTER** to select that setting.

- **MAX (MAXIMUM PROGRAMMABLE TEMPERATURE)**

The Maximum Programmable Temperature setting is a great feature to use when other people may be programming the kiln. It helps protect against an over fire by not allowing the programmer to input any value over the designated limit. To set your firing limit access the "MAX" setting through the "CNFG" menu, Input your desired limit and Press **ENTER**.

- **2KEY (2 KEYS TO START KILN)**

The "2KEY" feature allows you to set the controller so it takes two key presses to start the kiln. This helps protect against accidentally starting the kiln. When activated it will be necessary to press **START** then **ENTER** to start the program. To activate this feature access the "2KEY" setting through the "CNFG" menu, use the "1" key to toggle the setting to **ON** and Press **ENTER**. Now when you press **START** to begin the program you will see **----** on the display. At this point Press **ENTER** to begin the program.

- **dTCT (Detect Current Sensor Rating)**

This feature indicates the maximum amperage rating for the current sensor installed in your kiln. The current sensor is the hardware installed in your kiln which allows the controller to read the current from the outputs. This feature should not be modified without consulting a Skutt technician. Changing this setting will alter how the board interprets the current signal and will cause the board to produce erroneous current readings.

- **RSET (RESET TO FACTORY SETTINGS)**

Sometimes it is difficult to diagnose a kiln problem when factory settings have been modified. To reset the factory settings access the "RSET" setting through the "CNFG" menu and Press **ENTER**. The following settings will be restored.

- Error codes on
- TC offset set to zero
- Cone offset set to zero.

(OTHER)



The features contained in this menu heading are accessible only through direct contact with a Skutt technician. If you change from a Type S thermocouple to a Type K thermocouple or vice-a-versa you will need to change a feature setting in this menu section.



TROUBLESHOOTING YOUR KILN

WARRANTY WORK

All Skutt Kilns come with a Two Year Warranty which covers parts and labor. All warranty claims must be approved and serviced by an Authorized Skutt Distributor. If there is not an Authorized Skutt Representative in your area you may contact Skutt Kilns directly for authorization, however, labor costs will not be covered.

NON-WARRANTY WORK

Once the warranty has expired, many Skutt Kiln owners prefer to work on their own kilns to save money. We still recommend that you work closely with a Skutt representative to insure the diagnosis and repair are correct and done safely. There are a number of resources available to help you troubleshoot the problem efficiently and effectively.



YOUR LOCAL SKUTT DISTRIBUTOR

Your local Skutt Distributor should have a kiln repair technician on staff and replacement parts in stock. This is the best place to start since the call is local and you can often pick up parts that same day.

THE SKUTT FACTORY

Skutt has a well-trained staff at your disposal for technical support and information Monday through Friday from 8:00 AM to 5:00 PM Pacific Time. We will be happy to assist you with installation questions and troubleshooting of technical problems.

THE SKUTT WEBSITE

You also have a complete library of technical support information at your fingertips on our web site. To access this data just go to www.skutt.com, and click on the "Ceramic Kilns" tab. This will take you to the Ceramic Kilns Home page. Now go to the "Resources" tab in the top navigation bar and choose "Tech Support". Here you will find a whole library of documents on testing procedures, repair instructions and diagnostic tips.

With some basic guidelines and a general understanding of how your kiln functions, it is possible to safely diagnose and solve firing problems on your own. Just remember to be safe and ask for help when you need it.

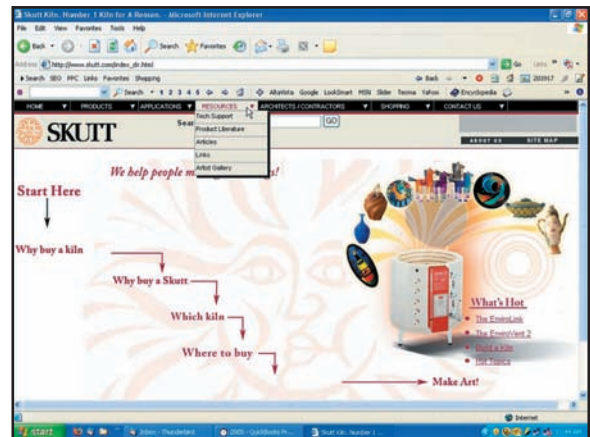

ERROR CODES

Error Codes are designed to protect your kiln and the ware inside your kiln if there is a problem with the firing.



In most cases when an error is triggered the kiln will shutoff and display E followed by the Error Code that describes the error that occurred. Non-critical errors will not stop the firing but they will display a code to notify you of the problem.

The following tables describe the error codes, their probable cause, and recommended solutions. If you run across a code that is not listed or you need help explaining, please give Skutt or your local distributor a call.

Error Code	Description
E- 0	Software Error.
E- 1	The temperature is increasing less than 12 degrees per hour during a ramp segment, where the temperature is programmed to increase. This slow rate must persist for 22.5 minutes before the error is displayed
E- 2	During a hold segment the temperature rises to greater than 50 degrees above the hold temperature which was set. The temperature must stay 50 degrees above this set temperature for 18 seconds before the error is displayed.
E- 3	During a hold segment the temperature is more than 50 degrees below the hold temperature which was set. The temperature must stay 50 degrees below this set temperature for 18 seconds before the error is displayed.
E- 4	The firing is in a ramp segment where the temperature is programmed to decrease and temperature is more than 50 degrees above the previous hold temperature. The temperature must remain 50 degrees above the hold temperature for 18 seconds before the error is displayed. E- 4 is the same as E- 2 except that E- 4 occurs during a ramp phase rather than a HOLD
E- 5	The temperature is more than 50 degrees below the local set-point temperature during a ramp segment where the temperature is programmed to decrease. The temperature must stay 50 degrees below this set temperature for 18 seconds before the error is displayed.
E- 6	A Negative temperature is displayed. This generally indicates the thermocouple is connected incorrectly. To correct this situation, ensure the red and yellow wires are connected correctly to the controller and at all junctions. You can identify the red lead on an unmarked thermocouple with a magnet because a magnet will be attracted to the red lead.

Causes	Correction
Caused by hardware or electrical noise, can be caused by electrical spikes, surges, or arcing across the relay	Recheck the selected program, and reprogram if necessary.
Worn or old heating elements Low voltage to the kiln A broken heating element or faulty relay Burned or broken wires to the elements or relays Electrical noise	Check elements. Check Relays Use VOLT Menu feature to check voltage.
Stuck relay.	If only one section (or relay) remains on then it is a stuck relay. Turn of breaker to shutoff power to the kiln.
Opening the door or lid of the kiln. Relay or element failed during firing.	Check relay. Check elements.
Stuck relay Skipped step feature	Check relay If E- 4 occurs when skipping a ramp phase, press a key to clear the error. Allow the kiln to cool to within 50 degrees of the next hold temperature. Restart kiln and skip steps until you get to the segment you want.
Open door or lid Bad elements Bad relay	Check elements. Check relay.
Using the kiln in temperatures below 0 degrees °F (17 degrees °C) Thermocouple (T/C) connected backwards, red and yellow leads reversed. Board has been damaged by static electricity or ESD (electro static discharge)	Check T/C to make sure it is connected properly. Do T/C bypass test, if temperature reading is still negative, the board has been damaged and needs service.

Error Codes	Descriptions
E- 8	When using the CONE FIRE MODE, the temperature is decreasing during the last ramp segment. If this a KilnSitter Kiln using a Wall Mount Controller, KilnSitter may have shut off the kiln
PF	Continuous PF in display.
Err P	A continuous Err P indicates a short term power outage has occurred and the kiln has continued with the program.
Err-	The Err with a dash indicates there was a power loss to the controller while writing a program to the non-volatile memory chip.
E- E or E- t	A hardware error has been detected by the controller software.
E- d	The kiln or one of the zones in a zone control kiln, is more than 100°F (37°C) above the travelling set point.
E- A	Invalid Program variable
StUc	Key was held too long or was stuck
E- bd	Controller is reading a board temperature above 160 degrees. Firing has stopped.
E- H	Analog to Digital Converter did not pass the self – check diagnostic test on reset.
FAIL	Steady display all thermocouples (T/C's) have failed. If flashing thermocouples of a zone control kiln has failed.

Causes	Correction
Faulty relay Broken Element KilnSitter Shut-off kiln	Check relay. Check Elements Check Cone used in KilnSitter
Indicates a long-term power outage The kiln has been shut down.	Press 1 to clear the display and restart the kiln.
Power Outage Power Surge	Press 1 to clear the display If firing was in progress, it will continue.
Power loss	Recheck the selected program, and reprogram if necessary.
Hardware error	The controller must be returned for service.
Stuck relay	Check relay
	Reprogram if problem persists have board sent in for service
	If problem persists after releasing key have keypad replaced
Room temperature is too hot..	Lower room temperature below 100°F (37°C)
	Board will need to be serviced
	Change T/C

QUESTIONS AND ANSWERS

How can I correct a value that's been incorrectly typed before pressing ENTER?

Clear the display by pressing all zeros, then input the correct number and press **ENTER**. When a cone value has been incorrectly entered the process is slightly different. After pressing **0000**, press **ENTER**. The display will again ask for a preheat value and then a cone value.

How can I change only one value for a RAMP/HOLD firing profile without re-entering the whole program?

Follow the instructions for entering a new program and just press **ENTER** for every value that will remain the same. Make a change in the value that is incorrect, then continue.

How can I change the program after it has already started?

Press the **STOP** key. This will stop the firing. Use either the CONE FIRE MODE or RAMP/HOLD MODE to input the new firing profile for the remaining portion of the firing. Press **START** to resume the firing. The controller will automatically determine where to start the program (based on the current internal temperature) and proceed with the adjusted program.

The kiln shuts off too early.

The kiln can be restarted if the cones on the shelf indicate an under-fired load. (This should be used only if you were present when the kiln fired off.) The cones are no longer accurate if they have cooled much from the time of shut off. To restart follow these steps.

- Press **CONE FIRE** or **RAMP/HOLD** to view the firing just completed.
- Press **ENTER** to accept any of the segments that are correct until the point where the cone number or final firing temperature is requested.
- Program in a hotter cone or higher firing temperature. You could also add a few minutes of hold time at the final firing temperature.
- Press **START** after the reprogramming is complete. The kiln will begin firing based on current temperature and will fire to completion using the newly programmed data.
- *Helpful hint* If the firing is just slightly under fired, program five minutes of hold time at the final firing temperature. This will allow the sections of the kiln that are somewhat cooler to catch up to the hotter sections.

The kiln displays CPLt but the kiln won't cool off.

Check the elements to see if any are still glowing inside the kiln. If a whole section of the kiln is glowing, a relay is stuck. Unplug the kiln and contact your distributor for further information.

At night I see a blue flash coming out of the control box when it clicks. Is it serious?

The flash occurs when the contacts open causing a small arc. This is a normal occurrence and should not be a concern.

I PROGRAMMED A RAMP/HOLD PROFILE AND WHEN I PRESSED START, THE ALARM SOUNDED.

Review the program to ensure that all segments of the profile have a value entered. Also, check the alarm to see if a value has been entered that is lower than the room temperature. The default setting for no alarm to sound is **9999**.

The kiln is plugged in, but there is nothing on the display.

First check your circuit breaker to ensure it has not tripped. If the circuit breaker is okay, check the fuse. The fuse is located on the bottom of the KM 1 Controller and on the lower left side of the kiln mounted controller. Turn the knob a quarter turn counter-clockwise to remove the fuse. Check the fuse wire, and if broken, replace the fuse. If the fuse is smoky, replace it. After the fuse is replaced, if the new fuse blows, check for other possible causes. A blown fuse may be caused by a short in the circuit or a power surge.

Some segments of the display are dimmer than others.

When a few segments of the LED-display become dimmer than the others, the problem may be the result of age, indicating the circuit board may soon fail. Another possible cause is exposure of the controller to high heat. This situation needs attention. Do not use the kiln when this problem is present. Contact your distributor.

The thermocouple is flaking.

Flaking is normal with Type K thermocouples, especially when high fired. Use a soft bristle toothbrush to remove the flakes and vacuum them from the kiln so they do not attach to your ware. Remove the thermocouple element periodically and check it for thinning.

The end firing temperature is different now than when I first got my kiln and the results do not seem quite right. What should I do?

After about 50 Cone 6 firings, or 150 Cone 04 firings, it is necessary to replace the thermocouple element. When the temperature seems to drift, it is an indication that the thermocouple is becoming thinner and wearing out. Another possibility is a cone correlation difference. As elements age it takes longer and longer for the kiln to reach temperature. ConeFire Mode programs will automatically lower the ending temperature to compensate for the added heat work induced by the increased time.



PREVENTIVE MAINTENANCE

ALL KILNS

Vacuum floor and element grooves regularly. Carefully vacuum around thermocouple and elements. Leave KM kilns plugged in when you are vacuuming to ground any static charges that may occur at the nozzle tip of the vacuum. Try to keep the vacuum away from the touch pad area.

- Inspect Plug and Wall receptacle for any indication of excessive heat. Replace both plug and receptacle if necessary.

KM KILNS

- Inspect the thermocouple for cracks or bends which could cause failure. Check and tighten thermocouple screw connections at the porcelain block. The thermocouple electronic circuitry may drift out of calibration. You can monitor the performance of your kiln with witness cone placed in the kiln. If the controller needs adjustment to fire hotter or cooler you can program a cone fire offset adjustment on the controller.
- Inspect connections at the terminal strip. If any feeder wire or thermocouple connections are loose you can tighten the screws that hold the tabs with the tabs in the most counter-clockwise position possible. If the connectors are loose do not pinch the female connectors with a pliers replace them. Pinching can distort and minimize the electrical contact area in the connector.
- KM1231-3PK and KM1227-3PK have screw type element connectors at the element ends that may need tightening periodically.

KILN SITTER (KS) KILNS

- The tube assembly should be inspected and cleaned of any debris in the tube. The sensing rod should move freely in the tube.
- The sensing rod should be replaced if the tip is worn too thin or otherwise damaged.
- The falling weight and claw adjustments should be checked with the gauge washer periodically.

TIGHTENING STAINLESS STEEL BANDS

This operation is done while the kiln is cool and at room temperature.

STEP 1

- Grasp adjusting screws in one hand with channel locks or a pair of vise grips.

STEP 2

- With other hand, Use a large flat screwdriver to tighten adjusting screws.
- To make bands extra tight, heat metal bands with a propane torch. Be sure to only heat the metal bands, and not the firebrick. Once the band is heated retighten screws.



REPAIRS

The premium brick used in Skutt walls will withstand thousands of firings without crumbling. Broken element grooves are usually the result of carelessness in handling the kiln sections or in loading shelves.

It's almost impossible to cement a broken groove lip back into place without contaminating the heating element. If the element starts to sag out of position, hang it on 1.5 inch element pins inclined toward the back of the groove.

CAUTION: Elements become very brittle after a few firings, so if straightening is necessary, heat the element electrically to visible redness, unplug the kiln from the wall and immediately push the element back into position with a metal implement, reheating whenever stiffening is detected. Place your hanging pins in a straight row and the element will serve the rest of its normal life.



REPLACEMENT OF WALL BRICKS IS SIMPLE IN SKUTT KILNS

STEP 1

- Order needed bricks from the parts list available from your Skutt dealer. Replacement of terminal bricks involves cutting and renewing element connectors and should normally be postponed until it's necessary to replace that element.

STEP 2

- If repairing a top ring, disconnect the lid and remove all fittings from the jacket.

STEP 3

- Remove the screws that hold the control panel to the kiln. Swing the panel open. Slide the connectors off the terminal strip (they are pre-numbered for easy identification). Unplug the thermocouple tabs which are marked positive and negative. Lift the box straight up to remove it. Place on a clean flat surface.

STEP 4

- Place the ring, damaged side up, on a perfectly flat surface such as the kiln lid.

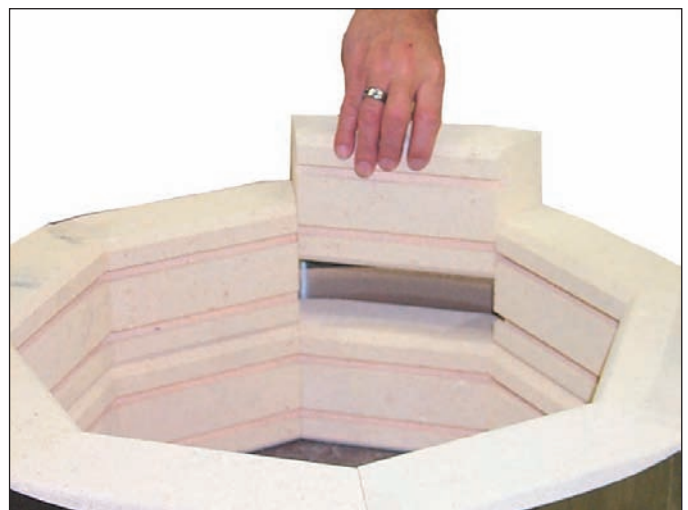

STEP 5

- Pull out the straight element pins at the ends of the damaged brick.

STEP 6

- Gently lift elements from troughs with a pick or long-nose pliers and gently lift them out into firing chamber just far enough to allow damaged brick to be slipped out. Remember that the elements are brittle.

STEP 7

- Loosen the worm-type jacket fasteners equally, .5 inch to .75 inch.

STEP 8

- Make sure element troughs in the brick are proper side up. Insert the new brick. This is easiest if a helper holds the adjoining bricks away.

STEP 9

- Hold the worm-type jacket fastener housings with pliers and tighten them evenly until they meet resistance.

STEP 10

- Use sandpaper over a wood block to sand the edges of new brick down flush with its neighbors. Vacuum thoroughly when sanding is completed.

STEP 11

- Replace hinges and hardware, and position the kiln so you can finish tightening the jacket just before the kiln shuts off on your next Cone 06 or hotter firing.

LID MAINTENANCE

Skutt lids are coated with a refractory cement which helps protect the kiln chamber from falling brick particles. This refractory coating will form hairline expansion cracks after the first few firings. This is normal and should not get worse over time. If your lid does develop a larger crack, you can use a thin coating of refractory cement to seal it. Large patch jobs are not recommended.

Remember to tighten the lid band and lid hardware on a regular basis. If the inside surface of the lid ever gets to the point where it is unrepairable you can flip the lid over. Just detach all of the lid hardware, flip the lid and reattach the hardware.

FLOOR REPAIRS

Glaze drips on a properly kiln washed floor can easily be removed without damage to the surface below. Remember to remove all glaze drips before taking the kiln to porcelain/stoneware temperatures, where the glaze will over-fire and soak through the kiln wash.

The floor can be patched if needed. If several square inches have been damaged to a depth of 5/8 inch or less, using a sharp knife or X-Acto tool, undercut the edges of the area to be patched. Use a spackling knife to fill the hole with kiln patch which can be purchased through Skutt. Sand smooth.

REPLACING ELEMENTS

While Skutt kiln elements are not difficult to replace, they require electrical connector tools. We recommend you ask your Skutt dealer about the procedure.

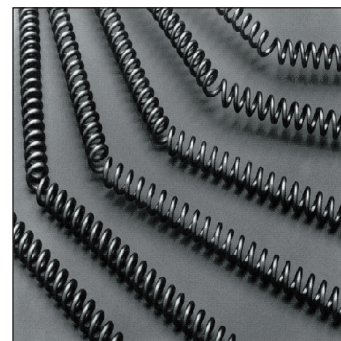
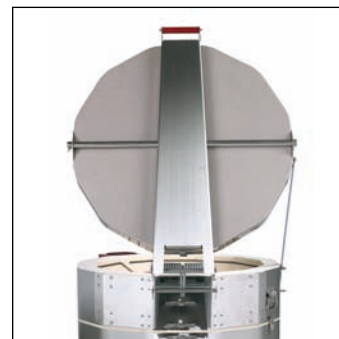

REPLACING THE THERMOCOUPLE ELEMENT ON KM AUTOMATIC KILNS

STEP 1

- Remove the screws that secure the red control box to the kiln.

STEP 2

- Swing the box open.

STEP 3

- The thermocouple has a yellow, insulated lead wire attached to the terminal strip with slide on connectors and marked with positive (+) and negative (-). **NOTE:** The negative (-) wire is red, not black!. Slide the connectors off the terminal strip.



STEP 4

- Remove the two screws that hold the thermocouple terminal block onto the heat shield.

STEP 5

- Gently pull the thermocouple assembly out of the brick.

STEP 6

- Loosen the two screws which hold the thermocouple element in place as shown in the picture at right and remove it from the thermocouple block.



STEP 7

- Insert the new thermocouple element in place and tighten the screws.

STEP 8

- Reattach the terminal block onto the heat shield with the two screws.

STEP 9

- Reconnect the thermocouple lead wire to the terminal strip, matching the positive and negative markings.

STEP 10

- Close the box



KILNMASTER CONTROLLER CIRCUITRY

The KilnMaster controller components are solid state and cannot be repaired in the field. If repairs are necessary, call the factory at **503-774-6000** to arrange repairs.

DO NOT SEND ITEMS WITHOUT PROPER AUTHORIZATION.

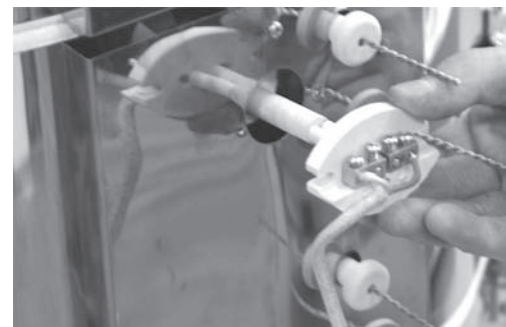

APPENDIX 1 — DISASSEMBLING MULTI-SECTION KILNS

ALWAYS UNPLUG A KILN BEFORE DISASSEMBLY

STEP 1

- Remove lid (See instructions on the next page.)

STEP 2

- Remove the screws on the left side of the control box that secure the box to the kiln, swing the panel to the side.

STEP 3

- Disconnect the numbered feeder and thermocouple wires from the terminal strip.

STEP 4

- Lift the control box up to remove it from the hinges and set it on a clean flat surface.

STEP 5

- Unbuckle the draw-pull catches between each section.

STEP 6

- LIFT EACH SECTION USING THE SECTION HANDLES AND PLACE ON A FLAT CLEAN SURFACE.



APPENDIX 2 — USING THE LID LIFTER

NEW LID BRACE

The lid brace has been redesigned with a two position setting and a stop post. The stop post is a safety feature which prevents the lid from opening too far and damaging the kiln. The lid brace provides additional safety and allows you to open the lid wider if needed for larger pieces.

LID LATCH

The Lid Latch serves two purposes. The first is to make sure the lid stays in the closed position while firing. To latch the lid shut, simply close the lid and swing the latch arm over until it pops into place. Be sure to latch the lid shut prior to every firing!

There are two additional venting positions that the lid can be placed in if the kiln is not equipped with a downdraft vent. Lift the lid up and swing the Lid Latch into the desired venting slot. When the kiln reaches 1000°F (537°C), close the lid and latch it shut. Always wear fireproof protective gloves when working with any hot kiln.

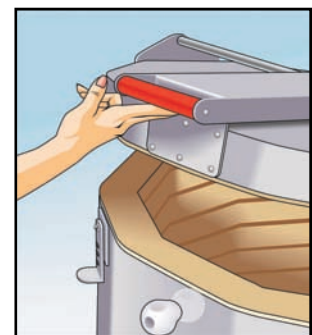

TENSIONING THE LID LIFTER

The Lid Lifter is shipped with the hinge springs de-tensioned in order to protect the lid during shipping. Please follow the instructions for tensioning the lid carefully to ensure success and avoid injury.

Step 1- Remove the Lid Brace

Remove the cotter pin and washer from the lid brace pad and remove the lid brace.



Step 2 - Remove Rod A & C

Remove the cotter pins on one side of Rod A and Rod C and with the lid closed slide out the rods.

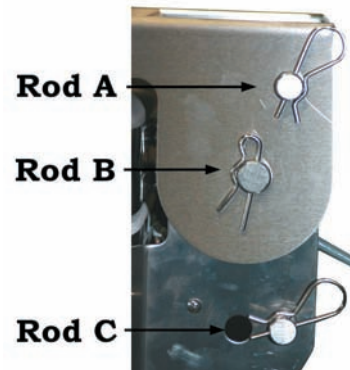

Step 3 - Re-insert Rod A

With lid closed, insert rod A with the springs in the position pictured below. Replace cotter pin.



Step 4 - Re-insert Rod C

Open lid all the way. (Lid will be heavy since it is not tensioned yet). Insert rod C as pictured below. Replace cotter pin. Lid is now tensioned. Close lid and replace lid brace.

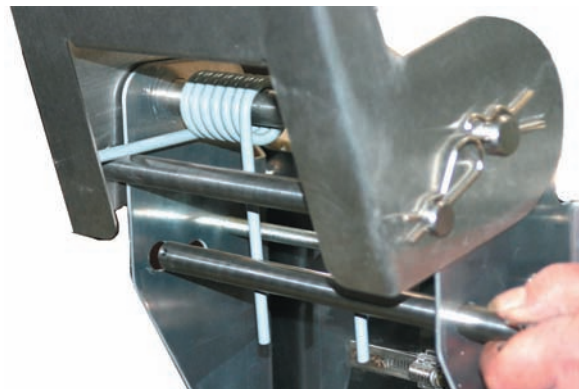

DE-TENSIONING AND REMOVING THE LID

To remove the lid it will be necessary to detension it first. Start by removing the lid brace and raising the lid as far as it will open. Next remove Rod C and close the lid. Be careful when lowering the lid since it is now de-tensioned. To remove the lid, remove Rod B and lift the lid straight up off the kiln.

APPENDIX 3 — HEATWORK

Heatwork is the measurement of the effects of time and temperature. In Ceramics, this measurement is gauged through the use of Pyrometric Cones. They are composed of materials which are carefully measured and compressed into the shape of a tetrahedron. The cones are placed in the kiln on a shelf with your ware and, when they have received the proper amount of heatwork, they bend over indicating that it is time to turn off the kiln.

Pyrometric Cones come in a variety of shapes and sizes. Each size and shape has a different temperature chart associated with it. The chart below is based on a Large Self-Supporting Cone and has become the standard for commercial clay bodies, glazes and controller software.

All clay bodies and glazes are designed to fire to a certain cone value. In a KilnMaster Kiln the computer calculates the heatwork and shuts the kiln off at the proper heat and time combination. This is called Cone Correlation. ConeFire Mode programs all are controlled by Cone Correlation, Ramp and Hold Programs are not

Skutt Kilns are designed to fire a range of cone values from 022 to 10. As you can see by the chart below, the temperature associated with each cone value gradually increases from 022 to 10. It is very important not to forget to add the leading zero when entering a cone value (if it is required) or the kiln will fire much hotter than you want it to.

Cone No.	°F	°C
022	1087	586
021	1112	600
020	1159	626
019	1252	678
018	1319	715
017	1360	738
016	1422	772
015	1456	791
014	1485	807
013	1539	837
012	1582	861
011	1607	875
010	1657	903
09	1688	920
08	1728	942
07	1789	976
06	1828	998
051/2	1859	1015
05	1888	1031
04	1945	1063
03	1987	1086
02	2016	1102
01	2046	1119
1	2079	1137
2	2088	1142
3	2106	1152
4	2124	1162
5	2167	1186
51/2	2197	1203
6	2232	1222
7	2262	1239
8	2280	1249
9	2300	1260
10	2345	1285

Remember that heatwork is the combination of time and temperature. This is most important during the last 200 °F of the firing. If the kiln is firing very slow during this period, the controller will automatically adjust the temperature down to ensure the ware does not receive too much heatwork. The cone values listed in the chart are only valid if the kiln is firing at exactly 108 °F/hr. during the last 200 °F of the firing. That is why it is very important to know the capabilities of your kiln when writing Ramp Hold Programs or entering Hold times.

We recommend that you still use Self Supporting Witness cones on every firing to monitor the accuracy of your kiln. Place the appropriate cone on a shelf approximately 2 inches from the kiln wall and two inches from the tip of the thermocouple. Make sure the space between the thermocouple and cone is unobstructed.

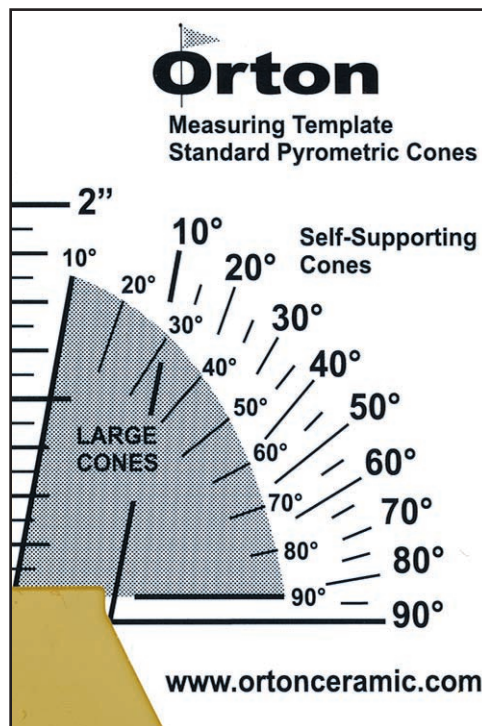

The Cone Measuring Template shown here can be used to determine the exact bend measured in degrees of angle. A perfect bend is considered to be at 90 degrees.

Remember that cones can vary slightly and are meant to be a general indicator of the heatwork within the kiln. Bends between 20 degrees and the tip of the cone just above the shelf are acceptable for most projects. If you find your bends are consistently low or high you can usually fine tune the heatwork by adjusting Hold times.



APPENDIX 4 — LOADING TIPS

- **BALANCE THE LOAD**

When planning how to load your kiln, keep in mind that the center of the kiln is generally the hottest. Therefore, you will want to distribute the load with the larger, thicker pieces towards the middle and the smaller, thinner pieces towards the top and bottom.

- **ALLOW THE KILN TO BREATHE**

Many studios work with glazes that require oxygen to develop properly. Provide enough space between items to allow them to “breathe. Using half shelves with a .25 inch space gap in the middle will also help increase the flow of oxygen within the kiln chamber, especially when used in combination with an EnviroVent

- **ALLOW FOR PROPER CLEARANCES**

Kilns lose most of their heat from the lid and the slab. Ideally, there should be at least two inches of space between the lid and the closest piece. The first shelf should be posted up one inch from the bottom slab.

- **NOTHING DIRECTLY UNDER THE ENVIROVENT HOLES**

Holes drilled in the lids of the kiln that have EnviroVents allow air to be drawn into the kiln chamber. If a piece of ware is sitting directly under one of these holes, it could leave a spot in the glaze. If it is not possible to cap the load with a shelf, leave a five inch radius on the shelf directly below each hole.

- **DO NOT RUSH**

Take the time to properly load and fire the kiln. Check each piece to insure that too much glaze or unsteady placement will not cause disaster during the firing. A few extra minutes can save you a lot of frustration.

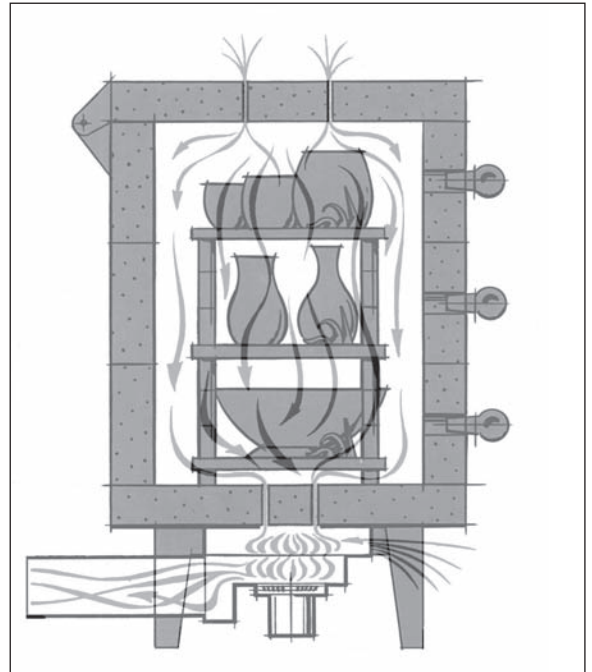

APPENDIX 5 — ELECTRICAL REQUIREMENTS

Most important to proper operation of your new kiln is to make sure it has enough of the correct power to operate. If this is done, your kiln will give you years of satisfying service; if not, your first firing could be disappointing or even disastrous for your kiln. The specification charts on the following pages show the recommended electrical specifications for each kiln model.

If you are uncertain about your existing outlets, have them checked by an electrician. If you are installing a new receptacle, have the electrician follow this guide:

NEMA-RECEPTACLE GUIDE

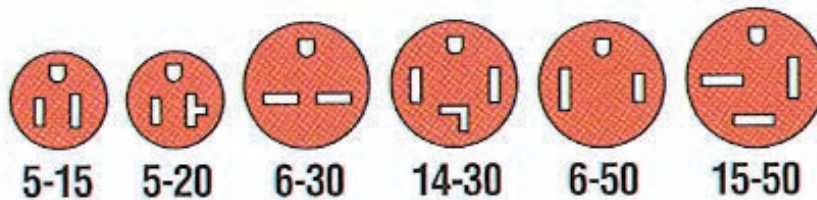

THREE-PHASE OPERATION

Only special order Models KM 1027 and KM 1227 will operate on a three-phase supply. However, any Skutt kiln can be properly powered via unbalanced connection to two of the three hot wires of a three-phase supply. Of course, the green safety ground connection provided in all Skutt power cords is also used. Three-phase Models KM 1027 and KM 1227 can be plugged directly into a three-phase (15-50R) wall receptacle.

VOLTAGE

As you can see from the chart, most Skutt models are available in either 208 or 240 volt versions. The exception is Model KM 714 which is universal, and will fire with 240V or 208V power.

The "120/208V" supply is increasingly encountered in schools and newly-built communities, because it's more efficient for heavy 120V loads. This affects Models KM 818, KM 818-30A, KM 1018, KM 1027 and KM 1227 because their elements receive the full 208 (or 240) applied volts. The 208V versions should never be fired on a 240V supply without first installing a full set of 240V elements. Otherwise, all components will be seriously overtaxed.

714 Wiring

Important: The wall outlets for Model KM 714 must be powered by 3-wire 120/240-208V solid neutral supply—as for an electric range. Only No. 10 wire is required for runs under 50 feet. 30 Amp fuses or circuit breakers only—no larger or smaller—are recommended. The U-shaped fourth blade of the 4W30 Amp grounding plug is for the pure green wire grounding of the kiln case. The blade opposite this U-shaped one takes the white solid neutral wire.

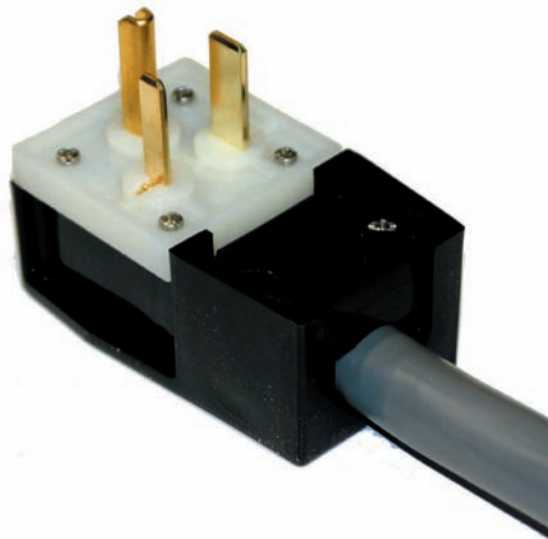

KILNMASTER KILNS AND WALL MOUNT CONTROLLERS

Model	PH	Volts	Amps	Watts	Copper Wire Size*	Fuse or Breaker Size	NEMA Receptacle
KM614	1	115	20	2300	10	30	(Canada) 5 – 30
KM614	1	115	20	2300	10	30	5 – 20
KM714	1	208-240	20	3600	10	30	14 – 30
KM818	1	240	27.8	6672	8	40	6 – 50
KM818	1	208	26.7	5554	8	40	6 – 50
KM818-30A	1	240	21.7	5208	10	30	6 – 30
KM818-30A	1	208	24	4992	10	30	6 – 30
KM1018	1	240	39.4	9456	6	50	6 – 50
KM1018	1	208	40	8320	6	50	6 – 50
KM1027	1	240	48	11520	6	60	6 – 50
KM1027	1	208	48	9984	6	60	6 – 50
KM1027	3	240	29.3	11520	8	40	15 – 50
KM1027	3	208	31.7	11000	8	40	15 – 50
KM1218	1	240	48	11520	6	60	6 – 50
KM1218	1	208	48	9984	6	60	6 – 50
KM1218	3	240	29.3	11520	8	40	15 – 50
KM1218	3	208	29.5	9984	8	40	15 – 50
KM1227	1	240	48	11520	6	60	6 – 50
KM1227	1	208	48	9984	6	60	6 – 50
KM1227	3	240	29.3	11520	8	40	15 – 50
KM1227	3	208	31.7	11000	8	40	15 – 50
KM-1	1	208-240	Switching Capacity 48 AMPS				6 – 50
KM-1	3	208-240	Switching Capacity 40 AMPS				15 – 50

***For each additional 50 feet use heavier wire,** numerically two numbers lower—for example, instead of #10, use #8. If you anticipate installing any larger kiln in the future, use the heavier wire. Electrical specifications listed above are suggested guidelines. Local electrical codes may vary.

PK SPECIFICATIONS

Model	PH	Volts	Amps	Watts	Copper Wire Size*	NEMA Receptacle	Fuse or Breaker Size
KM1227PK	1	240	60	14400	4	Direct Wire	80
KM1227PK	1	208	69	14352	4	Direct Wire	90
KM1227PK	3	240	40	14300	6	Direct Wire	50
KM1227PK	3	208	46.7	14300	6	Direct Wire	60
KM1231PK	1	240	72	17280	2	Direct Wire	90
KM1231PK	1	208	80	16640	2	Direct Wire	100
KM1231PK	3	240	44.5	17300	6	Direct Wire	60
KM1231PK	3	208	51.5	17300	6	Direct Wire	65
KM1627PK-LF	1	240	68	16320	4	Direct Wire	85
KM1627PK-LF	1	208	69	14352	4	Direct Wire	90
KM1627PK-LF	3	240	46	16300	6	Direct Wire	60
KM1627PK-LF	3	208	47	14300	6	Direct Wire	60
KM1627PK	3	240	66	23600	4	Direct Wire	85
KM1627PK	3	208	76	23600	4	Direct Wire	95

***For each additional 50 feet use heavier wire,** numerically two numbers lower—for example, instead of #10, use #8. If you anticipate installing any larger kiln in the future, use the heavier wire. Electrical specifications listed above are suggested guidelines. Local electrical codes may vary.

APPENDIX 6 — SET-UP AND SPECIFICATIONS FOR SKUTT PK KILNS

PK PRODUCTION KILNS

Skutt PK production kilns are heavy duty, high capacity units designed to meet the needs of the high fire production potter, tile maker and light industrial user. These kilns are equipped with upgraded components and wiring that will allow them to high fire extremely dense loads in a relatively short time.

FIRING

Skutt PK kilns feature our KilnMaster controller, so operation is identical to other KM kilns. Even though the earlier sections of this manual do not refer specifically to the PK kiln line, you may follow all the instructions on programming and firing routines.



KILN IMPROVEMENTS

If you are an intensive kiln user, you might find a PK kiln to be the appropriate choice for your next kiln purchase. Here are some the differences from our standard KM kiln line

First, PK kilns are designed to fire full, Cone 10 loads without stalling on the high end. To do so, they are equipped with industrial gauge wiring and three types of elements for better firing balance. Because of their high rating, electrical codes require that they be direct wired by an electrician; therefore no plug is included. Mercury displacement relays are used for longer life and quieter operation.

The hinged control box is larger, and compression connectors are used on the feeder wires for easier element replacement.

Finally, Model KM 1231PK comes with an additional stand for bottom slab support under heavy loads.

UNPACKING AND MOVING PK KILNS

Follow the general instructions on kiln set-up found in this manual. You will probably want to separate the kiln into sections when you set it up or move it to a different location. These instructions are slightly different than for standard KM kilns.

CAUTION: Before disassembling any PK kiln, be sure to turn off power to the kiln by throwing the circuit breaker or removing the fuse on its circuit. Do not restore power to the kiln until it is fully reassembled.

NOTE: The mercury relays in the switch box must be operated only with the switch box in a normal, vertical orientation.

TO SEPARATE A PK KILN INTO SECTIONS

STEP 1

- Refer to page 37, Removing the Lid Lifter, for instructions on Lid Lifter assembly.

STEP 3

- Remove the screws from the side of the red control box and swing the panel to the side.

STEP 4

- Number the feeder wires using tape so you can remember where they will be reconnected.

STEP 5

- Loosen the terminal block lugs that hold the feeder wires. These are located on the fiberglass lined heat baffle. Remove wires from the three terminal blocks.

STEP 6

- Slide the thermocouple connectors off the terminal strip.
- Lift the red control box up to remove it.

STEP 7

- Unhook the draw pull catches and lift the sections using the handles provided.

TO REASSEMBLE PK KILNS

STEP 1

- Stack the sections in original sequence.

STEP 2

- Place the switch box on its hinges.

STEP 3

- Reattach the feeder wires in their original positions. *Make sure the connection is very tight to avoid electrical problems.*

STEP 4

- Reattach the thermocouple wires in their original position, positive to positive and negative to negative.

STEP 5

- Reattach the screws which secure the control box to the kiln jacket.

APPENDIX 7 — SETUP FOR THE KM 1627

The 1627 will be packed in three separate boxes which will include the following:

Box 1

- KM 1627

Box 2

- 3 Piece Fiber Slab Insert
- 12 — 1 inch (2.54 centimeter) Posts

Box 3

- 2 Piece Kiln Stand
- 6 Peep Plugs
- "Goodie Bag"
- Operating Manual
- Warranty Card
- 12 Plastic Stand Feet
- Lid Prop



SET UP

Follow the general instructions on kiln setup in the Set Up section of this manual. There are three main differences that should be noted when setting up the KM 1627:

- Due to the weight of the KM 1627, you will want to separate the kiln into sections when you set it up.
- The KM 1627 has two stands that fit together for greater support. Place the stands flush together
- The KM 1627 includes a three piece rigid fiber liner that fits inside the bottom section on top of the slab. There are holes cast in the liner which hold the 1 inch (2.54 centimeter) ceramic posts. Carefully lay the fiber insert on top of the slab after the first section is placed in position and insert the posts.

CAUTION — Before disassembling any Oval kiln, be sure to turn off power to the kiln by throwing the circuit breaker or removing the fuse on its circuit. Do not restore power to the kiln until it is fully reassembled.

DISASSEMBLING THE KM1627

STEP 1

- Remove the screws from the left side of the control box.

STEP 2

- Swing open the control box open.

STEP 3

- Remove the screws holding the feeder wires to the two pole blocks on the heat baffle.

There are three sets with two feeder wires going into each set.

STEP 4

- Remove the thermocouple wires from the thermocouple terminal strip on the baffle.
*They are attached with slide on connectors and should be pulled straight off.
Pulling at an angle can damage the connector.*

STEP 5

- Lift the box up and set it aside.
- Unfasten draw pull catches and lift sections apart using the handles

TO REASSEMBLE KM 1627**STEP 1**

- Stack the sections in original sequence and secure the draw pull catches.

STEP 2

- Place the control box on its hinges.

STEP 3

- Reattach the feeder wires to their corresponding block.
- Making sure the connection is tight to avoid electrical problems.

STEP 4

- Reattach the thermocouple wires in correct order.

STEP 5

- Reattach the screws which secure the control box to the kiln jacket.

KM 1627		
Section	Element Type	Position
Upper	Top/Bottom	1
	Top/Bottom	2
	Intermediate	3
	Intermediate	4
Master	Center	5
	Center	6
	Center	7
	Center	8
Lower	Intermediate	9
	Intermediate	10
	Top/Bottom	11
	Top/Bottom	12

APPENDIX 8 — THE WALL-MOUNTED KILNMASTER CONTROLLER

The wall-mounted KM-1 KilnMaster gives automatic kiln control to most modern Skutt 208/240V kilns and any other brand kiln which uses NEMA 6-50 (single phase) or NEMA 15-50 (3-phase) plugs and receptacles. It can be moved quickly from one kiln to another and can control virtually any kiln in a studio which has the proper cord plug and receptacle configuration.

Once installed, the KilnMaster controller uses the same operating instructions as other Skutt Automatic kilns. Choose a location that will put the controller at least two feet from the kiln to prevent overheating the controller. To mount the controller, mark the hole positions on the wall where the controller will be installed using the paper template supplied with the controller and follow these instructions:

STEP 1 – TO MOUNT THE CONTROLLER ON STUD OR POST

- Use the holes marked **A** on the template and screw a #12 x 2 inch wood screw into the wall leaving a .25 inch gap.
- Repeat for the second screw.

TO MOUNT THE CONTROLLER IN SHEET ROCK

- Using holes marked **A** and **B** on the template, drill the necessary holes to properly mount the .25 inch x 2 inch molly bolts into the sheet rock.
- Tighten the first bolt until there is a 1/8 inch gap.
- Repeat for the other three bolts.

Before hanging the controller on the wall, loop the cord attached to the quick reference card over a screw so that it hangs below the controller when mounted.

STEP 2 – CONNECTING TO THE KILN

• SINGLE-PHASE

(Switching capacity 48 Amps on 208-240V) To operate the wall-mounted controller, simply engage the kiln plug in the receptacle located on the back of the controller. Then plug the controller into the existing wall receptacle.

• THREE-PHASE

(Switching capacity 40 Amps on 208-240V) To connect your three-phase kiln, plug the power cord from the kiln into the receptacle mounted on the back of the controller. Plug the pilot cord (the smaller cord) into the small receptacle mounted on the underside of the controller. The controller is plugged into a wall receptacle which provides three phase voltage. You will no longer need to use the three-phase contractor box. However, an electrician may need to wire a receptacle for the controller if a three-phase contractor box was used previously. You may need to make other changes to the supply for kilns not made by Skutt. Other manufacturers may not use pilot cords. Please discuss this with your distributor.



THERMOCOUPLE INSTALLATION

Skutt kilns have a hole stamped in the stainless band where the thermocouple flange is to be installed. It is located to the right of the red switch boxes. The firebrick is visible through this hole. The thermocouple flange is a metal tube approximately 5/8 in. (1.59 cm) diameter and 1.5 in. (3.81 cm) long attached to a metal washer.

- Remove the thumbscrew from the flange.
- Align the thermocouple flange so that it is exactly over the hole in the stainless band.
- Position the flange so the thumbscrew is on the top.
- Attach the flange to the kiln using the two Phillips self-tapping screws provided.
- **NOTE** To start the screws, lightly hit each screw with a hammer until the point has pierced the stainless steel band.
- Insert a .5 in. (0.64 cm) twist drill or carpenter's bit through the flange holder.
- Slowly drill through the kiln wall brick into the kiln chamber
- Insert the thermocouple into the kiln so that 1.25 in.(3.18 cm) to 1.5 in.(3.81 cm) of the tip protrudes into the kiln chamber. Tighten the thumbscrew.
- Uncoil the yellow thermocouple wire that is hanging from the bottom of the controller enclosure.
- Plug the thermocouple ends into the receptacle coming from the controller. There is only one way the plug will engage the receptacle.
- The controller is now ready for use.

THEMOCOUPL E INSTALLATION IN A KILN NOT MARKED FOR A THERMOCOUPL E.

- Mark a .5 in. (1.27 cm) to 5/8 in. (1.58 cm) diameter hole on the stainless jacket in the center of the brick next to the Kiln-Sitter brick (one brick to the right of the master switch box). Be sure placement is accurate so that you do not drill through an element. Do not drill yet.
- Align the flange holder accurately over the mark, positioning the thumbscrew hole on top. Mark the position of the small holes on the jacket. Push hard or tap out with a nail and hammer the small screw holes. Drill two, 3/32 in (0.23 cm) holes for the smaller sheet metal screws. Drill through the metal only. Install the flange with the sheet metal screws provided.
- For the remaining installation steps consult the previous section on Thermocouple Installation for a Skutt Kiln.

STEP 3 – OPERATING INSTRUCTIONS FOR KILNS WITH A KILN - SITTER

The kiln switches, **KILN-SITTER** and **LIMIT TIMER** (IF SO EQUIPPED) NEED TO BE PROPERLY SET AND ADJUSTED FOR CORRECT OPERATION WITH THE CONTROLLER.

- Place a Junior cone one or two numbers hotter than the cone equivalent you program into the KilnMaster to keep the Kiln-Sitter from shutting off the kiln early. For example, if you program a Cone 5 (2156°) firing in the KilnMaster, place a Cone 6 or 7 Junior cone in the Kiln-Sitter.
- Push the plunger in. Repeat this procedure using new cones each firing.
- If your *Dawson Kiln-Sitter* is equipped with a limit timer, set the timer for 20 hours (the maximum). Because the KM-1 controller turns the power to your kiln on and off to control the temperature, the timer will only run intermittently and will be useless. If you fail to set a maximum time each firing, the timer may shut off the kiln early. You may want to disconnect the wires that operate the limit timer to eliminate the bother of resetting the timer each firing.
- Set all switches in your kiln to High. (Exception do not set the center section of the 818-WR above 4.)



APPENDIX 9 - PRIMARY DISPLAY MESSAGES

Messages displayed while accessing menu functions are described in the menu section of the manual. They are not listed below.

ALRM

The controller is asking for an alarm temperature to be entered between 0° and 9999° that will alert the operator to take action.

CONE

The kiln is in CONE FIRE MODE and needs the operator to input an appropriate Cone value from 022 to 10.

CPLt

The controller has completed a firing profile. The firing time in hours and minutes is displayed along with the current internal temperature of the kiln. press ENTER to return to Idle Mode.

dELA

This is a prompt to enter a time in hours and minutes to delay the firing before starting the program. Enter a time or all zeros for no delay.

E-##

A software error has occurred. Press any key to display the elapsed firing time and the temperature when the error occurred. Consult section on Error Codes for troubleshooting information.

F1, F2, F3, F4, F5, F6, F7 or F8

The controller is in RAMP/HOLD mode. The user needs to input an end temperature in °F or °C for **each** segment of the firing profile.

FAIL

The thermocouple and controller are not properly connected. Fix the connection, then Press **ENTER** to display the kiln's current temperature. Press Start after the connection is fixed. The thermocouple could be damaged. Check the connections, if still no luck you may need a new thermocouple.

HOLD

Indicates a holding time in hours and minutes at the end of a CONE FIRE program.

Hld1, Hld2, Hld3, Hld4, Hld5, Hld6, Hld7 or Hld8

The controller is in RAMP/HOLD programming mode. The user needs to input a period of time in hours and minutes that the controller should maintain for **each** segment of the firing profile.

-ON-

Briefly displayed at the beginning of firing to indicate that the kiln has started.

PROG

A prompt at the beginning of a RAMP/HOLD program which allows the user to select a stored program.

RA1, RA2, RA3, RA4, RA5, RA6, RA7 or RA8

The controller is in RAMP/HOLD programming mode. The user needs to input an appropriate temperature in °F/hr or °C/hr for **each** segment in the profile.

SEGS

(Looks like SE65) The controller is in RAMP/HOLD mode. The user needs to **Input** the number of segments in the profile being programmed.

SKIP

Short for Skip Step. Can be selected during a RAMP/HOLD program when one feels that adequate heat work has been done in the current segment. Immediately advances the program to the next segment.

SPd

The controller is in CONE FIRE MODE. The user needs to Input the appropriate speed; slow, medium or fast for this firing.

STOP

Designates the intentional termination of a program while in operation.

WAIT

Displays at the time the kiln is initially powered up. Wait for the display to return to Idle Mode.

Flashes twice at the end of programming while the controller is processing the information you have input.

FLASHING TEMPERATURE AND IdLE

The kiln is in Idle Mode. The kiln is off and the display is showing the kiln's current temperature.

ALTERNATING DISPLAY OF TIME AND TEMPERATURE

The kiln is in a RAMP/HOLD firing profile and is in the soak stage. The display is indicating the kiln's internal temperature and the remaining Hold time for that segment.

DECREASING TIME

The kiln is in a Delay start segment of a **CONE FIRE** or **RAMP/HOLD** mode. The display is showing the remaining time before the kiln starts to heat.

STEADY TEMPERATURE

The kiln is in the ramping stage of either a **CONE FIRE** or **RAMP/HOLD** fire profile.

DECIMAL POINT BETWEEN 10's AND 100's

Hours are to the left of the decimal and minutes are to the right.

RIGHT HAND DECIMAL POINT ON

Kiln is operating in Celsius temperature scale. To change back to Fahrenheit temperature scale consult the MENU Options.

KM614

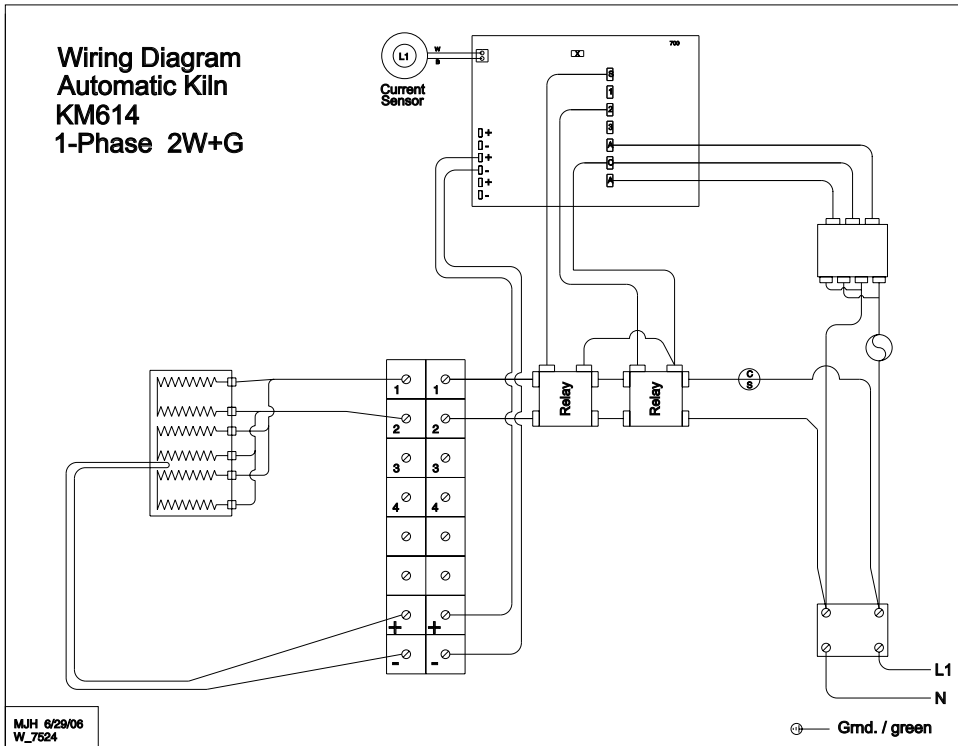

KM714

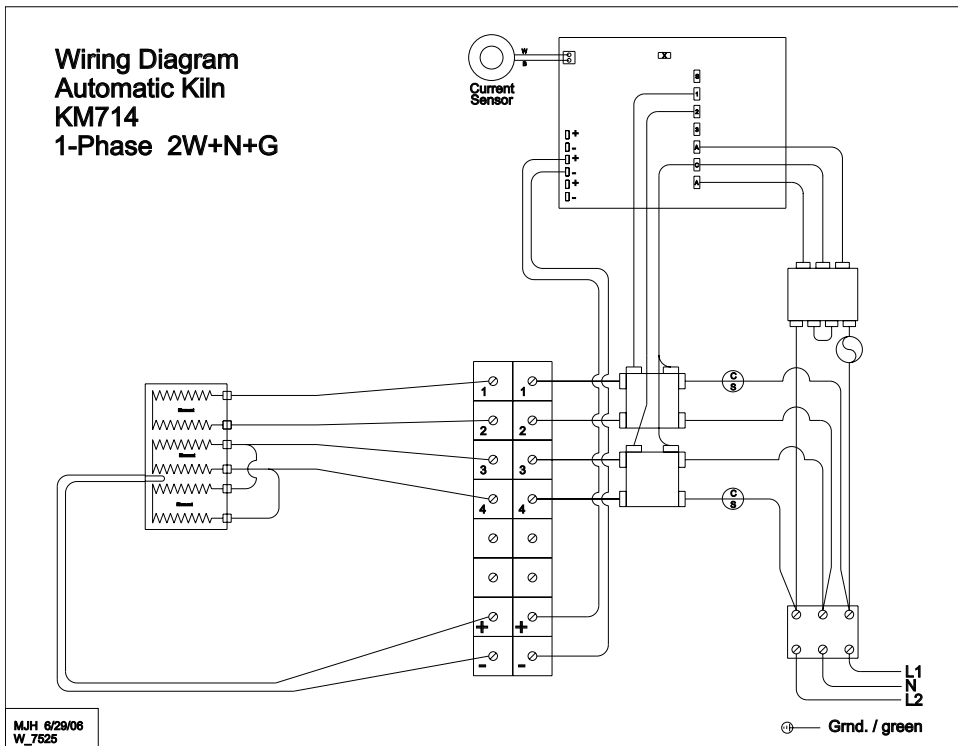

KM818, KM818-30A

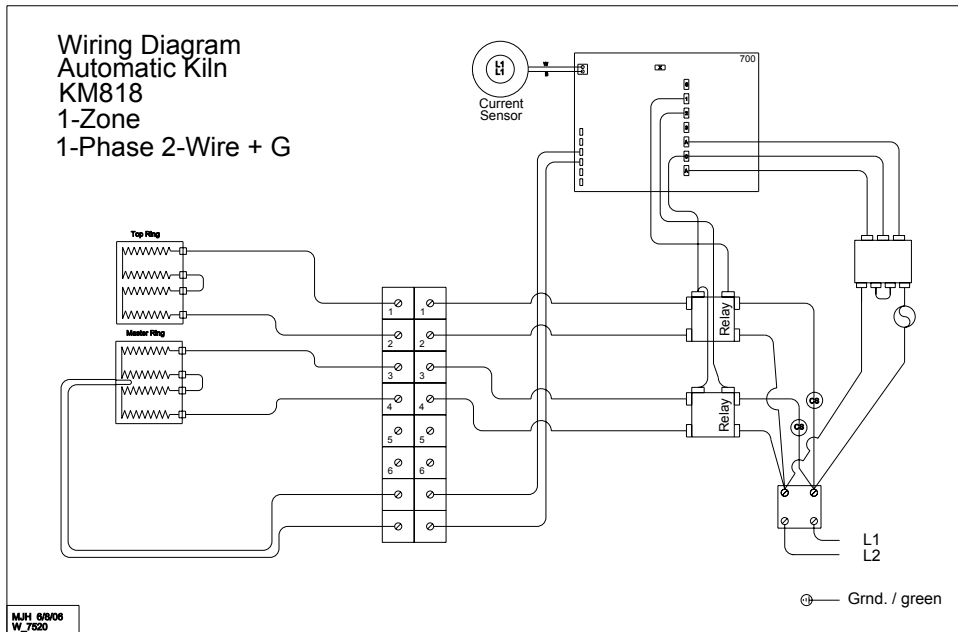

KM1018

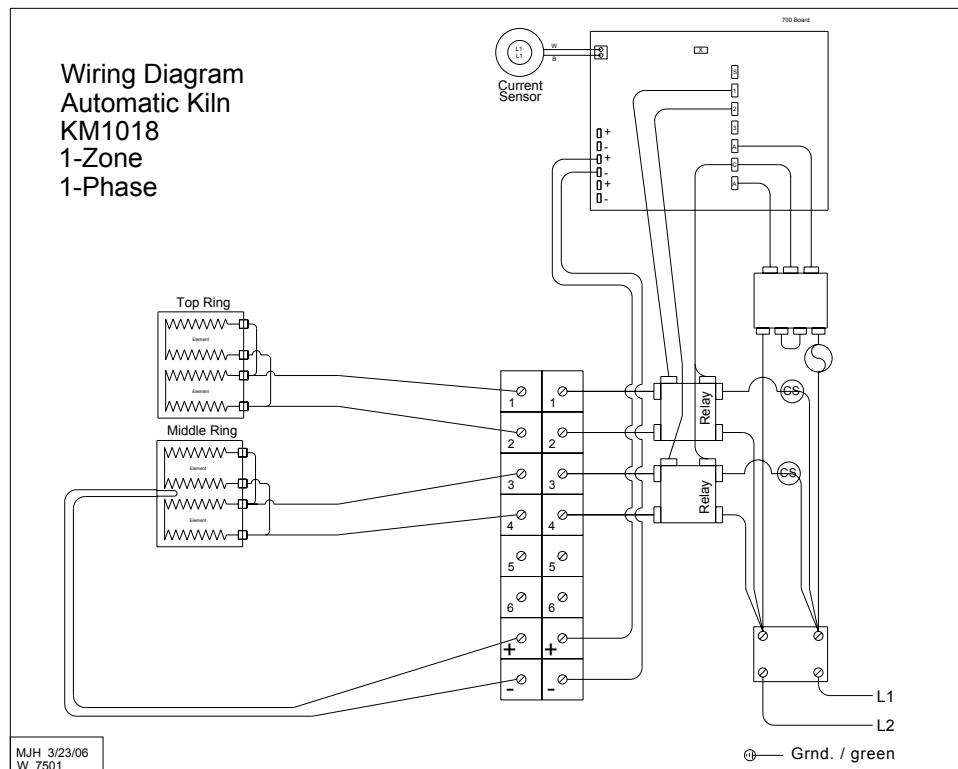

KM1218-3

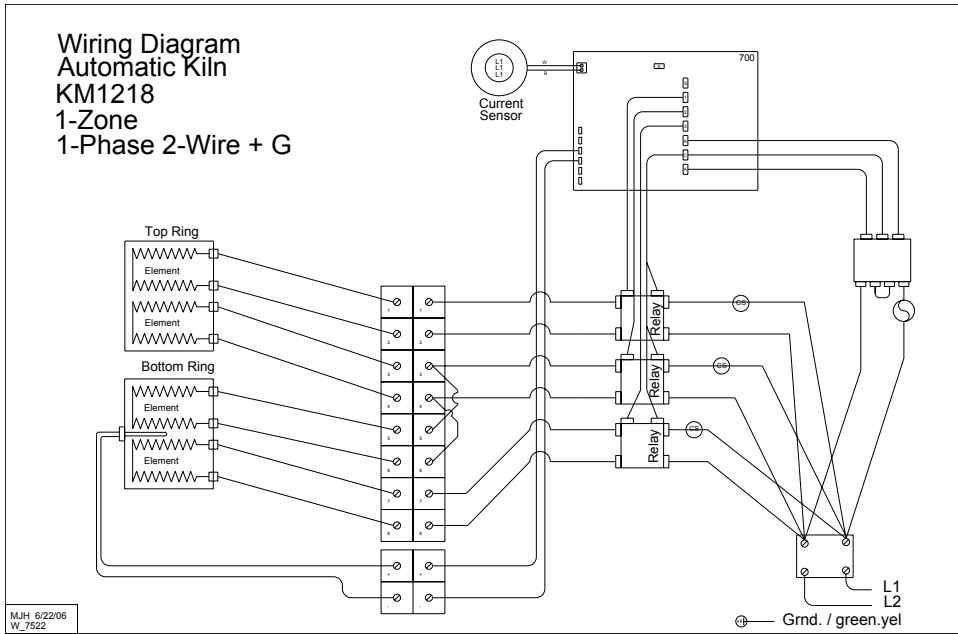

KM1218 3 PHASE

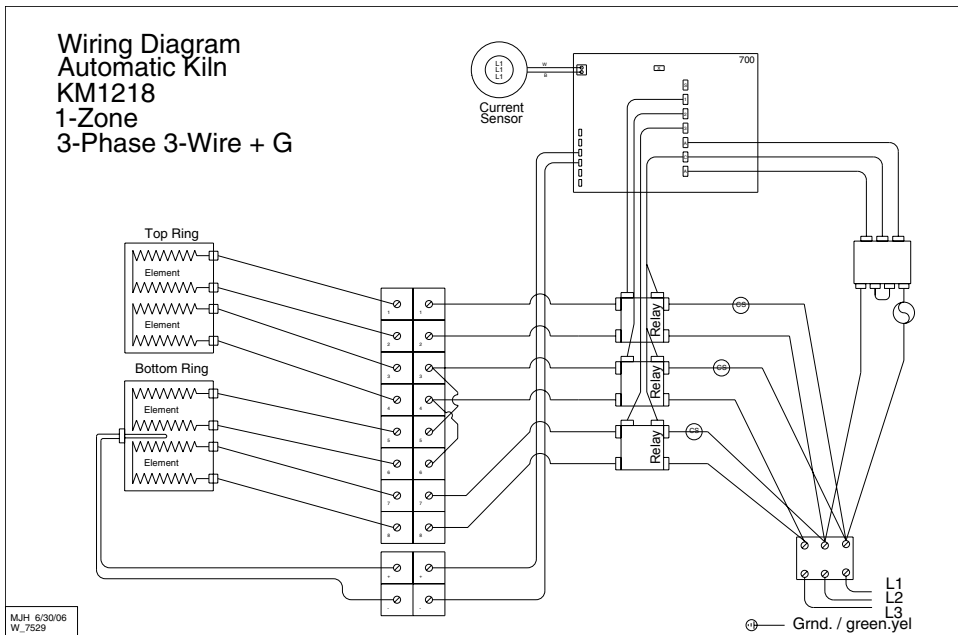

KM1027/KM1227

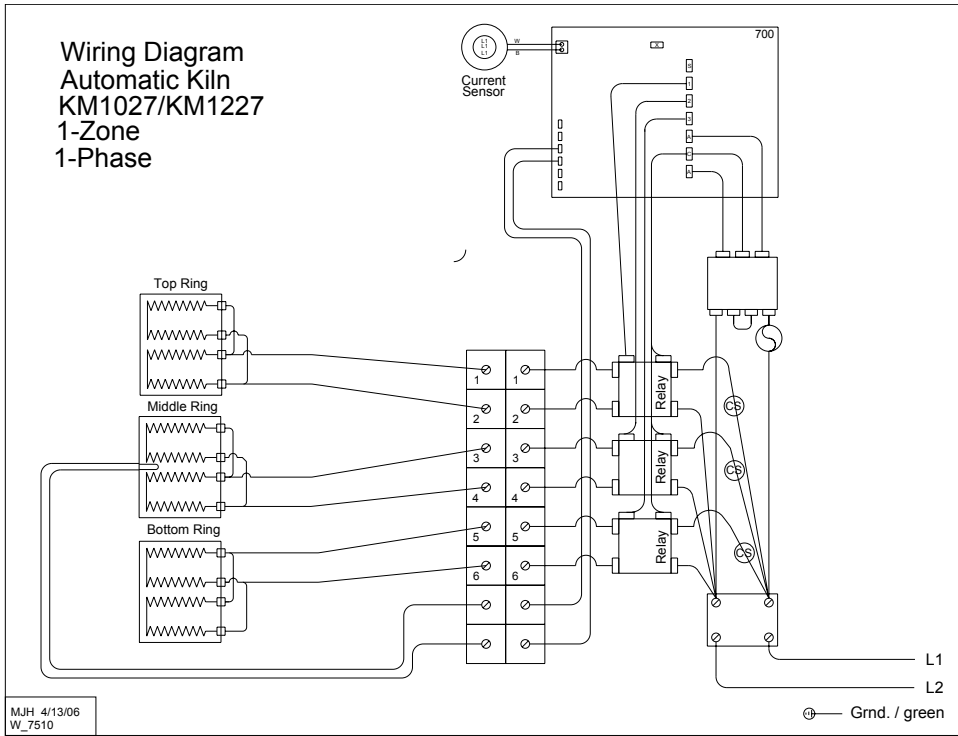

KM1027 3 PHASE/KM1227-3 PHASE

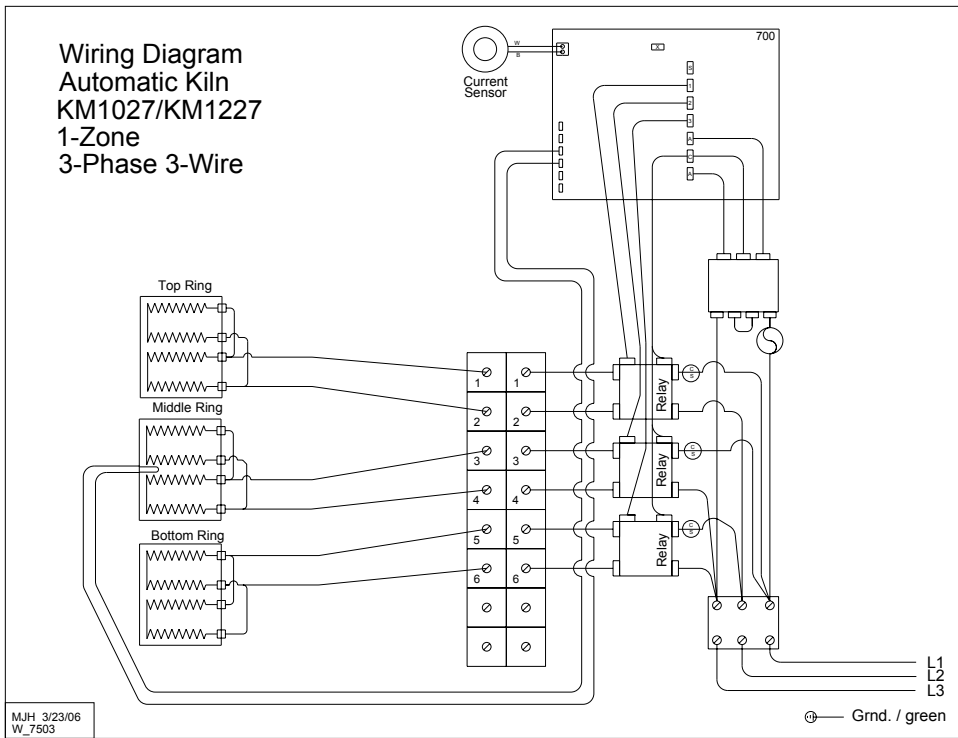

KM1227-3 PK

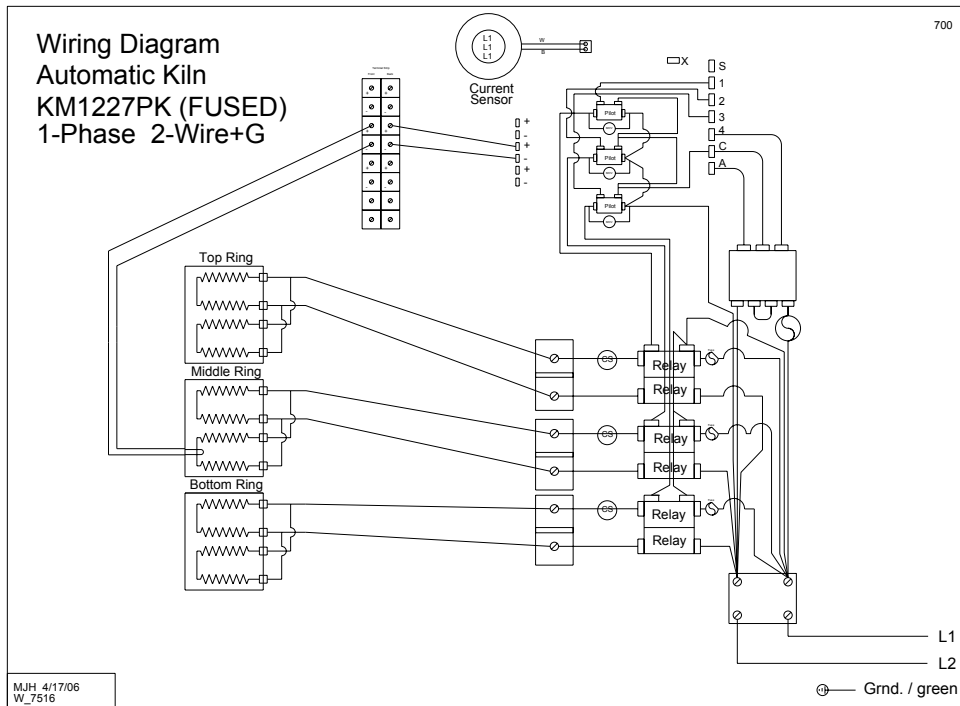

KM1227-3 PK 3 PHASE

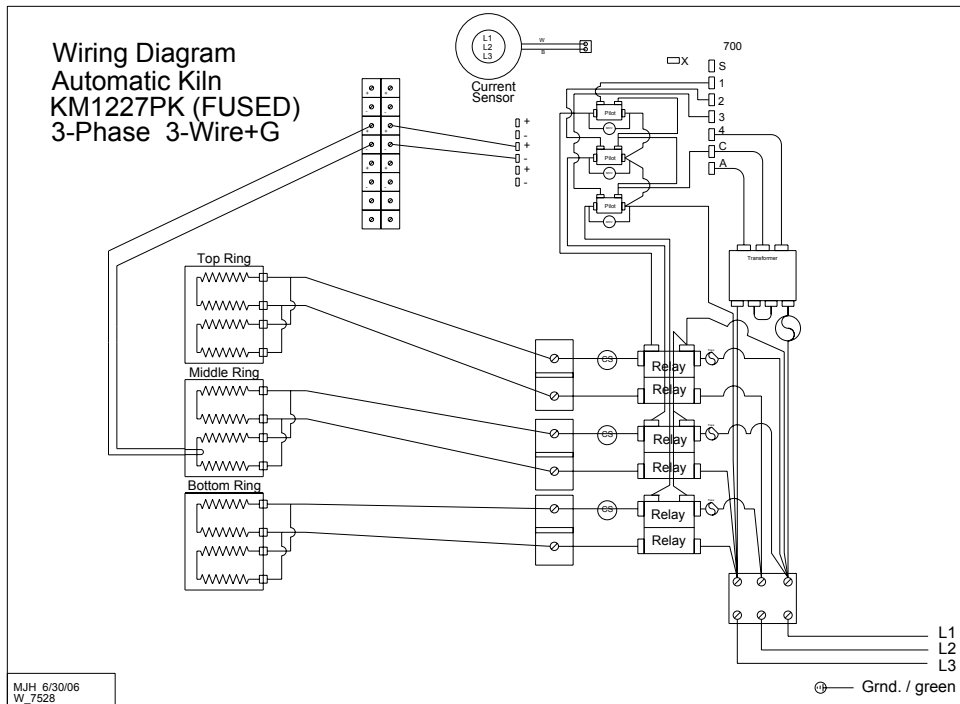

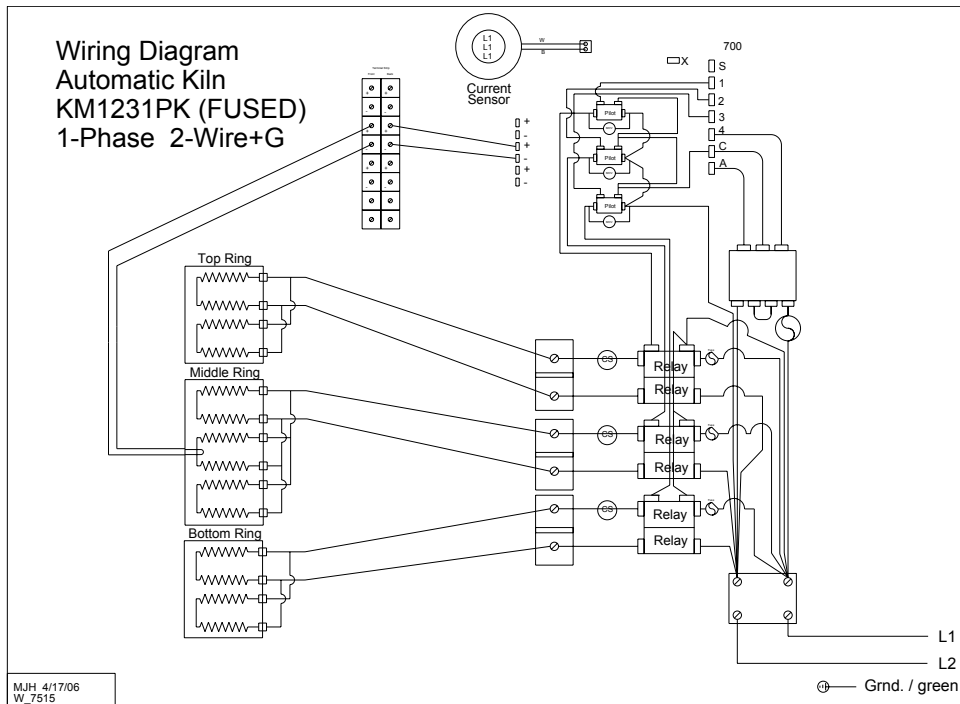
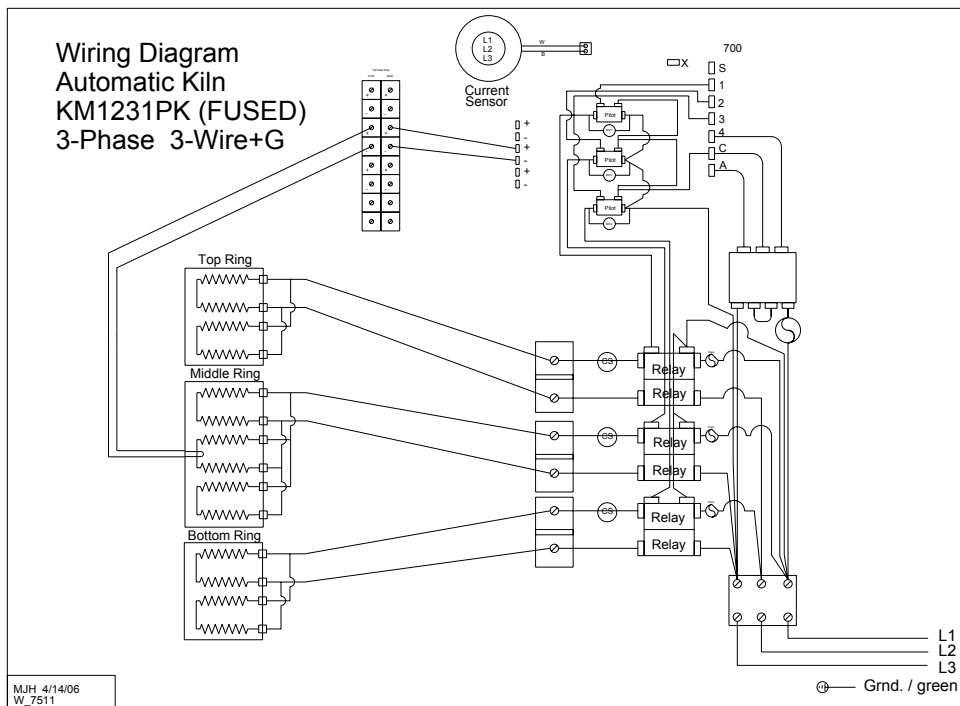
KM1231-3 PK**KM1231-3 PK 3 PHASE**

KM-1 1 PHASE

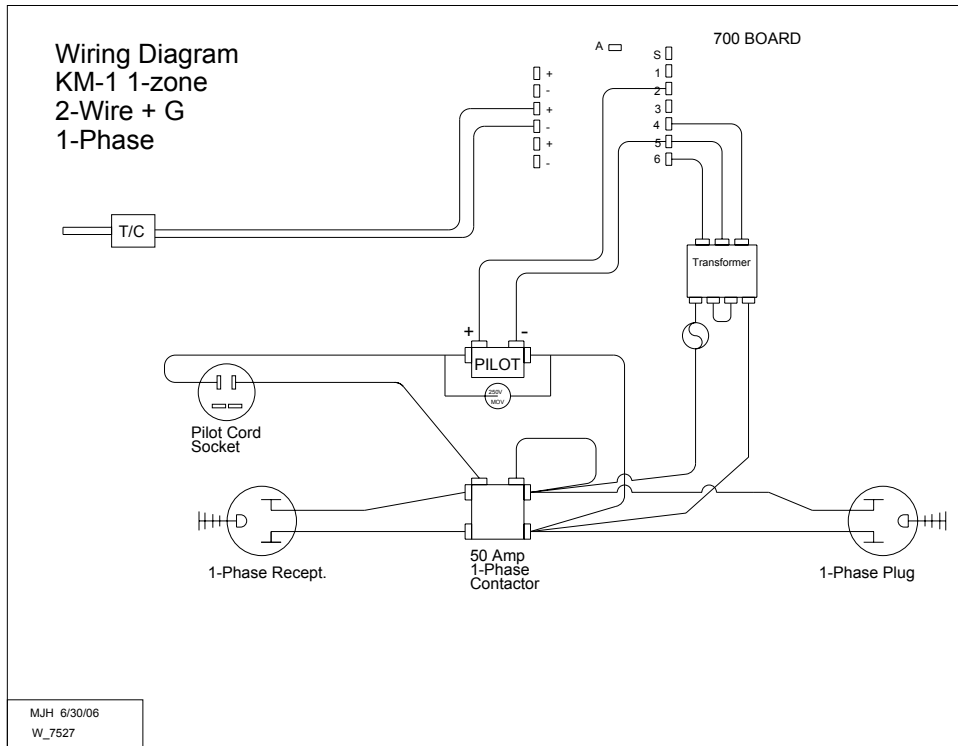

KM-1 3 PHASE

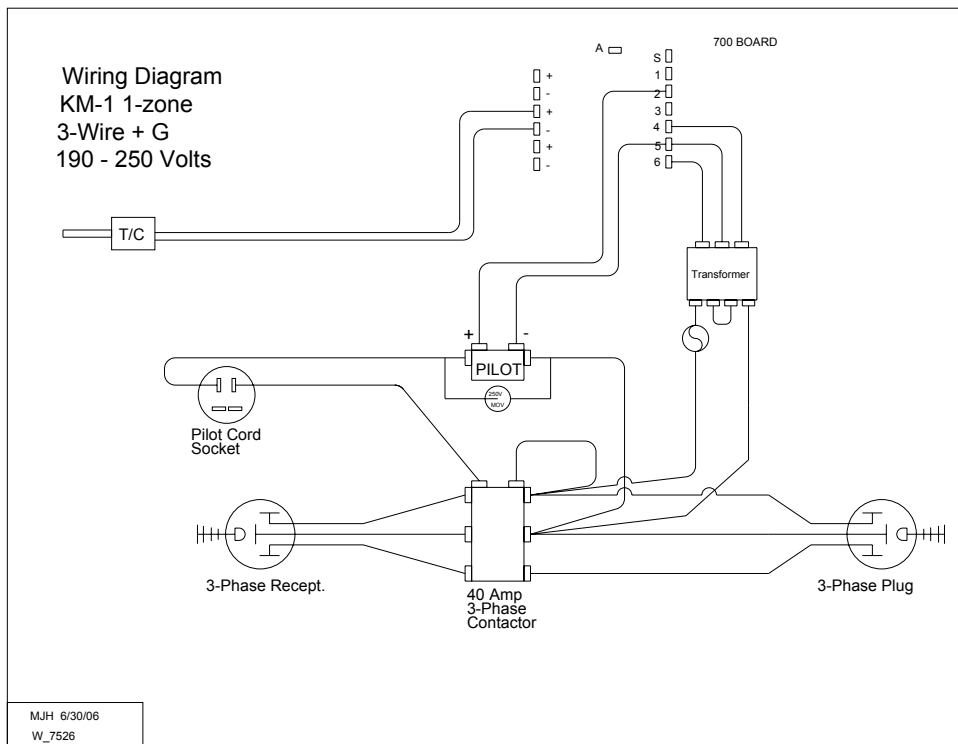

PROGRAM 1

SEGMENT	RATE	TEMP	HOLD	NOTES
1				
2				
3				
4				
5				
6				
7				
8				

PROGRAM 2

SEGMENT	RATE	TEMP	HOLD	NOTES
1				
2				
3				
4				
5				
6				
7				
8				

PROGRAM 3

SEGMENT	RATE	TEMP	HOLD	NOTES
1				
2				
3				
4				
5				
6				
7				
8				

PROGRAM 4

SEGMENT	RATE	TEMP	HOLD	NOTES
1				
2				
3				
4				
5				
6				
7				

PROGRAM 5

SEGMENT	RATE	TEMP	HOLD	NOTES
1				
2				
3				
4				
5				
6				
7				
8				

PROGRAM 6

SEGMENT	RATE	TEMP	HOLD	NOTES
1				
2				
3				
4				
5				
6				
7				
8				

PROGRAM 7

SEGMENT	RATE	TEMP	HOLD	NOTES
1				
2				
3				
4				
5				
6				
7				
8				

PROGRAM 8

SEGMENT	RATE	TEMP	HOLD	NOTES
1				
2				
3				
4				
5				
6				
7				

New Mexico Clay
3300 Girard Blvd. NE
Albuquerque NM 87107
505 881-2350

www.nmclay.com

6441 SE Johnson Creek Blvd.. Portland, OR 97206 (503) 774-6000 skutt@skutt.com

www.skutt.com